

SONY®

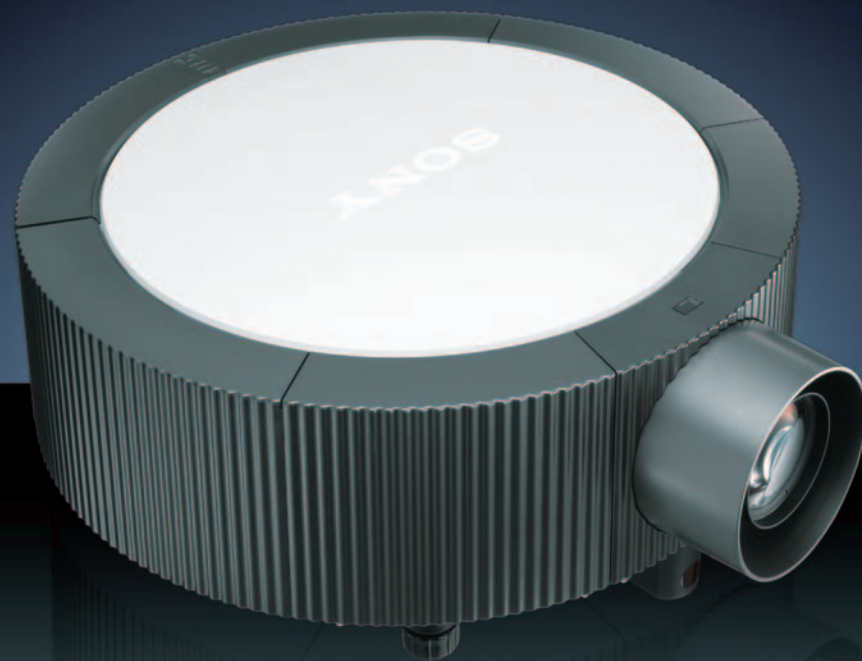

VPL-FH300L VPL-FW300L

In-room, Large-venue Projectors

www.sony.com/professional



BrightEra™

HDMI™
HIGH DEFINITION MULTIMEDIA INTERFACE

Dynamic 2K x 1K and WXGA Projections Powered by an Astonishing Brightness – the VPL-FH300L and VPL-FW300L Data Projectors

Packing the most advanced projector technologies into a uniquely designed round chassis, the VPL-FH300L and VPL-FW300L Data Projectors deliver extremely high-quality images of 2K x 1K and WXGA resolution, respectively.

These projectors also offer an incredibly high brightness of 6000 (VPL-FH300L) or 7000 (VPL-FW300L) lumens, thanks to the newly developed BrightEra™ LCD panel and a dual-lamp system.

The VPL-FH300L and VPL-FW300L adopt a bayonet mount that allows a lens to be easily attached and detached, and a variety of lens options are available to meet a range of installation needs.

System integrators will appreciate the projectors' design, which includes features for easy installation, such as a centered lens, simple cabling, and auto-flip image, as well as power zoom, focus, and shift, while maintenance personnel can easily replace lamps and filters at the same time, thanks to their easy access.

Furthermore, the VPL-FH300L and VPL-FW300L consume less than 820 W of power, which is the lowest level for projectors that provide the same level of brightness with a dual-lamp system.

With all of these features and functionality, which are only available from Sony, the VPL-FH300L and VPL-FW300L projectors are the best choice for a range of applications, from business conferences and seminars to education, simulations, and rental and staging, in locations such as boardrooms, large conference rooms, university classrooms, and art museums.



■ Features ■

High-quality Images

❖ Extremely High Resolution (2K x 1K or WXGA) in Widescreen

With a 2K x 1K LCD panel incorporated, the VPL-FH300L projects extremely clear and detailed high-quality images with a 2K X 1K (2048 x 1080)* resolution, even on a large widescreen. While the VPL-FW300L offers WXGA (1366 x 800) resolution for high-quality widescreen images.

*2K X 1K (2048 x 1080) signals supplied to the VPL-FH300L are converted to 2046 x 1080 signals by removing one vertical line from each side, and then processed and displayed as a 2K x 1K image.

❖ Outstanding Brightness (6000 or 7000 Lumens) From BrightEra LCD Panel and Dual-lamp System

The VPL-FH300L and VPL-FW300L Data Projectors achieve an outstanding brightness of 6000 and 7000 lumens, respectively. This allows for dynamic, large-screen presentations even in high ambient lighting environments. By combining a new generation of inorganic LCD panels that utilize Sony's BrightEra technology with a powerful dual-lamp system, these projectors offer both brilliant pictures and stable operations.

BrightEra Technology

BrightEra is a brand name for the category of next-generation LCD panels that have pixels with large aperture ratios and that adopt inorganic alignment films. Sony is the first manufacturer to succeed in developing this technology for a High-Temperature Polysilicon (HTPS) TFT LCD panel.



LCD Panel of the VPL-FH300L



LCD Panel of the VPL-FW300L

Dual-lamp System

The VPL-FH300L and VPL-FW300L adopt a unique lamp system that uses two lamps for reliable, flexible, and efficient use of light sources. In dual-lamp mode, the VPL-FH300L and VPL-FW300L offer a maximum brightness of 6000 and 7000 lumens, respectively. In single-lamp mode, users can select either of the two lamps manually, or the projector can automatically select a lamp based on each lamp's operating time.

In addition, the dual-lamp system enables virtually fail-safe operations. In dual-lamp mode, if one bulb burns out, the other can keep projecting images. In single-lamp plus auto-lamp-select mode, if one bulb burns out, the other automatically lights up to keep projecting images.

❖ 3LCD Projection System

Because the VPL-FH300L and VPL-FW300L adopt a 3LCD projection system, projected images are bright and natural. 3LCD is a projection system using three LCD panels. This system provides high light transmission and excellent color reproduction. It also provides smooth gradients in dark areas, and even helps prevent color breakup.

❖ Dynamic Detail Enhancer (DDE) for High-quality Video Images

This unique video-enhancing technology from Sony that is incorporated in the VPL-FH300L and VPL-FW300L generates high-quality images of outstanding clarity. For interlaced video sources, I/P (Interlace/Progressive) conversion is applied to the signals to project clear and sharp progressive images. When displaying film-originated sources, signals converted by 2-3/2-2 pull down are detected, and each frame of the original film is accurately reproduced.

❖ 12-bit 3D Gamma Correction and 3D Digital Comb Filter

The VPL-FH300L and VPL-FW300L incorporate 12-bit 3D Gamma Correction circuitry to perform highly accurate gamma correction, achieving uniform image color and brightness that extends light to the corners of the screen. What's more, the 3D Digital Comb Filter separates Y signals from C signals with great accuracy, which emphasizes fine images and shape boundaries.

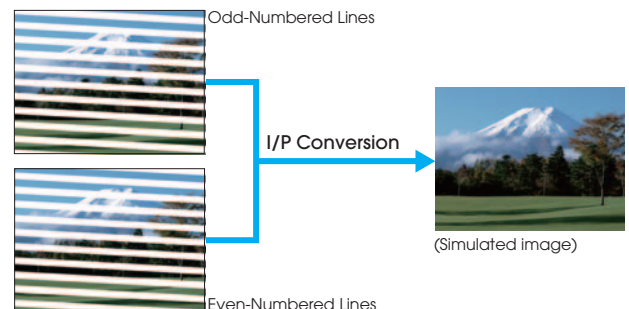

Installation Flexibility

❖ Round-body Design

The VPL-FH300L and VPL-FW300L adopt a unique and stylish round-body design that fits in well to any installation location. This design also provides the following benefits for system integrators to simplify installation of the projector.

Centered Lens Design

The centered lens incorporated in the round chassis of the VPL-FH300L and VPL-FW300L provides symmetry for a balanced installation, and makes setup very simple.

Carrying Holes

The VPL-FH300L and VPL-FW300L are equipped with carrying holes on their underside, situated along the rim of the round chassis. These carrying holes make it easy for system integrators to carry the projector.

Simple Cabling

Both the VPL-FH300L and VPL-FW300L have connector panels situated within their round body that are covered by connector-panel lids. These allow the user to hide any cables connected to the projector for a sleeker appearance. This can also be achieved when mounting the projector to a ceiling with the optional PSS-630 Projector Suspension Support, thanks to its cable covers.



Security Bars

The VPL-FH300L and VPL-FW300L are equipped with four security bars on their underside. A chain or wire can be connected to these security bars to help prevent the projectors from being stolen.

❖ Variety of Optional Bayonet-mount Lenses

The VPL-FH300L and VPL-FW300L adopt a bayonet mount that allows an optional lens to be easily attached and detached. This flexibility allows the VPL-FH300L and VPL-FW300L to be used for a number of applications – from long-distance projection in large auditoriums to short-distance rear-projection applications. The projectors are not supplied with a lens as standard, but any of the following five optional lens types can be selected.

❖ Power Zoom/Focus/Picture Shift (Horizontal and Vertical)

The Zoom, Focus, and Horizontal and Vertical Picture Shift functions available with the projectors' optional lenses* can be controlled from both the projector control panel and the supplied Remote Commander™ unit. Images can be easily adjusted to their desired settings both during installation and when the projector is in use.

* Not available with the optional VPL-4008 Fixed Short Focus Lens.

❖ Flexible Orientation

The VPL-FH300L and VPL-FW300L can be tilted 90 degrees upwards or downwards. This flexibility allows the projectors to be used in several different ways, including in a rear projection system.

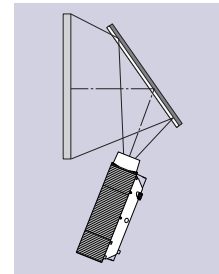

Rear Projection System

❖ Auto-flip Image

The VPL-FH300L and VPL-FW300L can automatically turn projected images upside down, thanks to a built-in angle sensor that can detect the orientation of the projector. This function is very useful for ceiling mount installations or rear projection systems.

■ Optional Lenses

	Fixed Short Focus Lens	Short Focus Zoom Lens	Standard Focus Zoom Lens	Middle Focus Zoom Lens	Long Focus Zoom Lens
	VPLL-4008	VPLL-Z4015	VPLL-Z4019	VPLL-Z4025	VPLL-Z4045
Zoom ratio	-	x1.3	x1.3	x1.9	x1.8
Throw ratio*	0.8:1	1.5:1 to 1.9:1	1.9:1 to 2.5:1	2.5:1 to 4.5:1	4.5:1 to 8.0:1
F-number	2.0	2.2 to 2.6	1.7 to 2.1	2.2 to 3.1	2.2 to 3.6
Screen size**	40-inch to 600-inch				60-inch to 600-inch

* Distance between the center of the projector lens and the screen, divided by the screen width.

** Viewable area measured diagonally.

Operational Convenience and Versatility

❖ Multiple Inputs

The VPL-FH300L and VPL-FW300L accept a wide variety of input signals – including component, composite video, S-Video (Y/C), computer analog signals up to UXGA (fV: 60 Hz), and digital signals up to 2K x 1K (fV: 24 Hz) – which expands system-connection possibilities greatly. The VPL-FH300L and VPL-FW300L are equipped with five BNC connectors, enabling them to accept signals from sources such as workstations and professional video equipment. Furthermore, these interfaces support long-distance signal transmission, allowing the sources to be located far away from the projector. The VPL-FH300L and VPL-FW300L are equipped with an HDMI™ interface that is the latest standard for digitally connecting to high-definition systems. In addition, with the optional BKM-FW16 HD-SDI Input Adaptor installed, the projectors can also accept HD-SDI/SD-SDI signals (from sources such as Sony's HDCAM™ VTRs and XDCAM™-HD/XDCAM-SD recorders) to project high-quality digital video.

Connector Panels (without connector-panel lids)

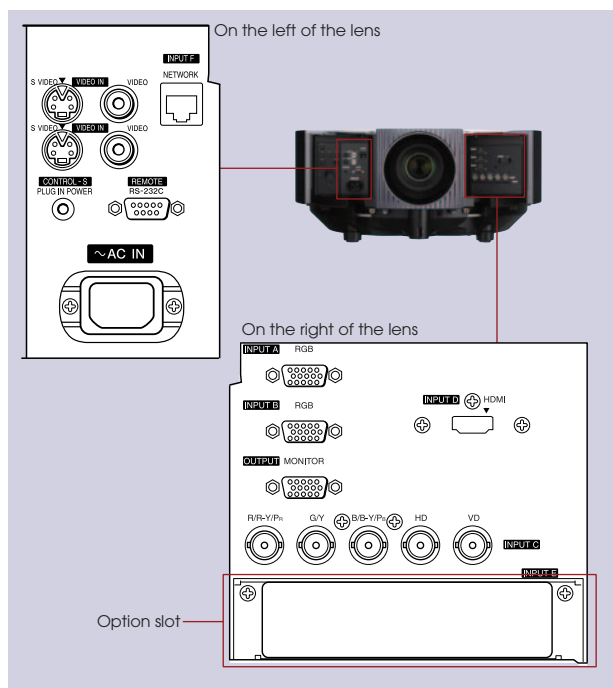

❖ Picture Muting Function via Built-in Mechanical Shutter

The VPL-FH300L and VPL-FW300L can interrupt the projection of images on a screen via a built-in mechanical shutter. This function can be easily operated with just the touch of a button on the supplied Remote Commander unit, and is very convenient for presentations in large venues such as board rooms and conference rooms.

❖ Monitor Output for Presenters

Projected images can be monitored by connecting a PC monitor to the VPL-FH300L and VPL-FW300L projectors' monitor output and placing it in the presenter's field of view. This allows the presenter to continually face the audience during the presentation for a fluid and professional delivery.

❖ Direct Power On

Activating this function allows the user to skip standby mode to power on the VPL-FH300L and VPL-FW300L immediately. Direct Power On is ideal for large-scale facilities such as museums, auditoriums, and conference halls, with images ready for projection as soon as the circuit-breaker on the switchboard is turned on.

❖ ID Function for Multi-projector Installation

The VPL-FH300L and VPL-FW300L have a built-in ID function, so each projector can be controlled independently from a single Remote Commander unit. For multi-projector installations in a single room, this feature is indispensable both during installation and operation.

❖ Multi-function Remote Commander Unit

The supplied Remote Commander unit for the VPL-FH300L and VPL-FW300L is useful for both setting up the projector during installation and changing settings for a presentation. This unit has buttons for direct input selection, so users do not have to toggle through the entire range of inputs to select the desired one. With the projector ID function, each projector in a multiple-projector installation can be controlled independently from a single Remote Commander unit.



❖ Network Presentation

When the VPL-FH300L and VPL-FW300L are installed on a LAN, presentations can be projected from any PC on that network* – whether connected via a LAN cable or wirelessly. Switching from presenter to presenter is as easy as clicking a mouse – there's no fussing with cables.

* Requires supplied application software to be installed on your PC.

❖ High-speed Image Transfer over IP Networks

Because the VPL-FH300L and VPL-FW300L employ efficient compression and transmission techniques, they can receive and project images via IP networks for effective presentations from any networked PC. In fact, they can even handle animated Microsoft® PowerPoint® presentations.

❖ Network Presentations Using up to Five Projectors

Up to five VPL-FH300L and VPL-FW300L projectors can be connected to a network, with the image from a single PC projected by each of them. This feature is ideal for both large venues and multiple rooms in which images have to be projected from various locations.

❖ Network Presentations Almost Anywhere

By manually registering a PC's IP address to the VPL-FH300L and VPL-FW300L, images can be projected not only across the country, but across the globe. This is ideal for applications such as distance learning and long-distance corporate communication.

■ Network Presentation System Diagram

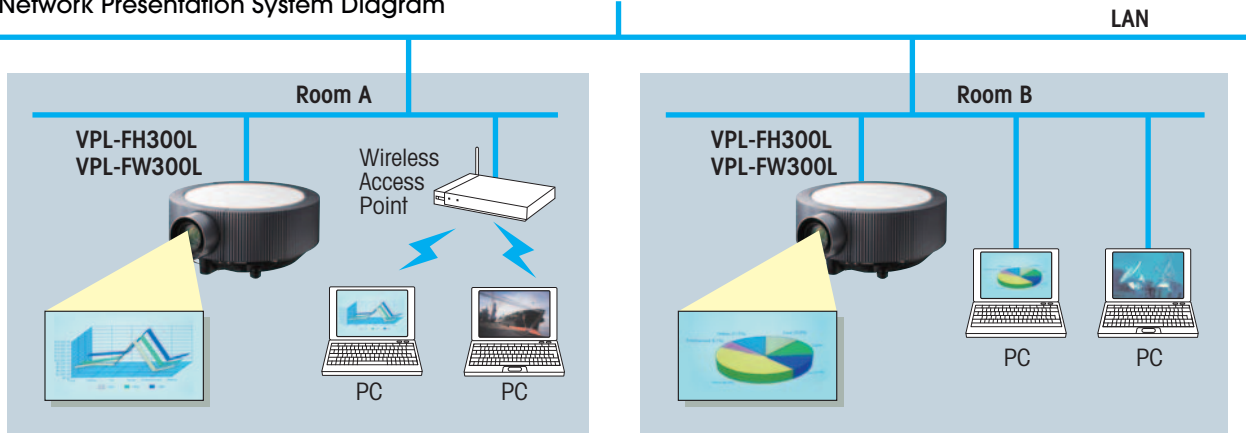

■ System Requirements to Run Supplied Software

Hardware	CPU: Intel® Pentium® III 600-MHz processor or faster, and and CPU recommended by OS
	Memory: 64 MB or more (128 MB or more is recommended), and Memory recommended by OS
	Hard disk: 10 MB or more of free capacity
	Other hardware requirements: CD-ROM drive
Operating System	Microsoft® Windows® 98 SE, Windows ME, Windows 2000, Windows XP Home Edition, Windows XP Professional Edition, Windows Vista Home Basic, Windows Vista Home Premium, Windows Vista Ultimate, Windows Vista Business
Browser	Internet Explorer 5.0 or higher
Display	Color resolution: 16-bit, 24-bit, or 32-bit
Network	RJ-45: 10BASE-T/100BASE-TX

Sony cannot guarantee that application software will run properly even though all of the above system requirements are met.

Notice Regarding Network Presentations:

- Animation effects and the slide show function in Microsoft PowerPoint presentations can be used; however, transmission delays may occur if a large number of effects are performed at once or if several slides are turned at once.
- Network transmission is not suitable for video.
- Network transmission should not be used with sound.
- Applications that use DirectX® application programming interface may not be displayed properly.
- When using Windows Vista, Windows XP or Windows 2000 Operating Systems, the user must be logged into an account with computer administrator access.
- Application software is provided in English and Japanese.
- Network presentations may not be possible depending on the network environment and available bandwidth.

Easy Maintenance

❖ Low Power Consumption (Environmentally-friendly Design)

The VPL-FH300L and VPL-FW300L consume less than 820 W of power, which is the lowest level for projectors that provide the same level of brightness with a dual-lamp system. In addition, these projectors offer a choice of two standby modes – standard and low – that minimize power consumption further. The standard mode and low mode of 30 W and 0.5 W of power, respectively.

This low-power-consumption allows operators to save significant electricity expenses in their operations.

❖ Easy Lamp and Filter Replacement

When it's time to replace the lamp and filters in the VPL-FH300L and VPL-FW300L, a timely message appears clearly on the screen. The lamp is accessible from the back of the projector and the filter is accessible from the side, so lamp and filter replacement can be performed without having to uninstall the projector.

Replacement filters are included in the optional LMP-F271 Projector Lamp, so both the lamp and filters can be replaced at the same time, saving maintenance time and cost.

❖ Lamp Memory Function

When exchanging the lamp of a conventional projector, operators typically have to reset the built-in timer that records the lamp usage hours. However, this is unnecessary with the VPL-FH300L and VPL-FW300L, because their lamps incorporate a memory that can record the lamp usage hours.

❖ Remote Operation and Maintenance Notifications via Network

Because the VPL-FH300L and VPL-FW300L can be connected to a LAN, a number of functions can be performed remotely using a web browser*. For example, the projector's current status can be verified and simple controls, such as powering the unit on or off, can be performed. Also, the system can be set up to send automatic e-mail reports to designated recipients for scheduled maintenance, including projected lamp life and error reports.

*Internet Explorer 5.0 or higher is required.

❖ Other Features

- Digital Keystone Adjustment
- Multi-language OSD (On-Screen Display)
- Smart APA (Auto Pixel Alignment)
- Password-authentication System

■ Optional Accessories ■



VPLL-4008
Fixed Short Focus Lens



VPLL-Z4015
Short Focus Zoom Lens



VPLL-Z4019
Standard Focus Zoom Lens



VPLL-Z4025
Middle Focus Zoom Lens



VPLL-Z4045
Long Focus Zoom Lens

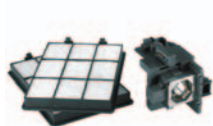

LMP-F271
Projector Lamp
(with filters included)



PAM-400
Projector Suspension
Support



PAM-400EXP
Projector Suspension
Support Joint Pole



BKM-FW16
HD-SDI Input Adaptor

■ Preset Signal Chart ■

No.	Preset signal		fH (kHz)	fV (Hz)	Sync
1	Video 60 Hz	Video 60 Hz	15.734	59.940	–
2	Video 50 Hz	Video 50 Hz	15.625	50.000	–
3	480/60i	DTV 480/60i	15.734	59.940	S on G/Y
4	575/50i	DTV 575/50i	15.625	50.000	S on G/Y
5	480/60p	480/60p (NTSC Progressive component)	31.470	60.000	S on G/Y
6	575/50p	575/50p (PAL Progressive component)	31.250	50.000	S on G/Y
7	1080/60i	1035/60i, 1080/60i	33.750	60.000	S on G/Y
8	1080/50i	1080/50i	28.130	50.000	S on G/Y
10	720/60p	720/60p	45.000	60.000	S on G/Y
11	720/50p	720/50p	37.500	50.000	S on G/Y
12	1080/60p	1080/60p	67.500	60.000	S on G/Y
13	1080/50p	1080/50p	56.260	50.000	S on G/Y
14	1080/24p	1080/24p	26.973	23.976	S on G/Y
15	1080/30p	1080/30p	33.750	29.970	S on G/Y
21	640 X 350	VGA mode 1 (VGA 350)	31.469	70.086	H-pos, V-neg
22		VESA 85 (VGA 350)	37.861	85.080	H-pos, V-neg
23	640 X 400	NEC PC 98	24.823	56.416	H-neg, V-neg
24		VGA mode 2 (TEXT) / VESA 70	31.469	70.086	H-neg, V-pos
25		VESA 85 (VGA 400)	37.861	85.080	H-neg, V-pos
26	640 X 480	VESA 60	31.469	59.940	H-neg, V-neg
27		Mac 13	35.000	66.667	H-neg, V-neg
28		VESA 72	37.861	72.809	H-neg, V-neg
29		VESA 75 (IBM M3)	37.500	75.000	H-neg, V-neg
30		VESA 85 (IBM M4)	43.269	85.008	H-neg, V-neg

No.	Preset signal		fH (kHz)	fV (Hz)	Sync
31	800 X 600	VESA 56	35.156	56.250	H-pos, V-pos
32		VESA 60	37.879	60.317	H-pos, V-pos
33		VESA 72	48.077	72.188	H-pos, V-pos
34		VESA 75 (IBM M5)	46.875	75.000	H-pos, V-pos
35		VESA 85	53.674	85.061	H-pos, V-pos
36	832 X 624	Mac 16	49.724	74.550	H-neg, V-neg
37	1024 X 768	VESA 60	48.363	60.004	H-neg, V-neg
38		VESA 70	56.476	70.069	H-neg, V-neg
39		VESA 75	60.023	75.029	H-neg, V-pos
40		VESA 85	68.677	84.997	H-neg, V-pos
41	1152 X 864	VESA 70	63.995	70.019	H-pos, V-pos
42		VESA 75	67.500	75.000	H-pos, V-pos
43		VESA 85	77.487	85.057	H-pos, V-pos
45	1280 X 960	VESA 60	60.000	60.000	H-pos, V-pos
46		VESA 75	75.000	75.000	H-pos, V-pos
47	1280 X 1024	VESA 60	63.974	60.013	H-pos, V-pos
48		VESA 75	79.976	75.025	H-pos, V-pos
49		VESA 85	91.146	85.024	H-pos, V-pos
50	1400 X 1050	VESA 60	65.317	59.978	H-neg, V-pos
51	1600 X 1200	VESA 60	75.000	60.000	H-pos, V-pos
55	1280 X 768	1280 X 768/60	47.776	59.870	H-neg, V-pos
56	1280 X 720	1280 X 720/60	44.772	59.855	H-neg, V-pos
60	1360 X 768	1360 X 768/60	47.720	59.799	H-neg, V-pos
61	1440 X 900	1440 X 900/60	55.935	59.887	H-neg, V-pos
62	1680 X 1050	1680 X 1050/60	65.290	59.954	H-neg, V-pos
63	1280 X 800	1280 X 800/60	49.702	59.810	H-neg, V-pos

- Preset signal Nos. 1, 2, 21-25, 27-31, 33-35, 38-43, 46, 48, 49, 51, and 56 are analog only.
 - Preset signal Nos. 12-15 are digital only.
 - Images may not be reproduced correctly when signals other than those listed above are input.
 - Contact your local Sony sales office for more information regarding signals not listed.

■ Dimensions ■

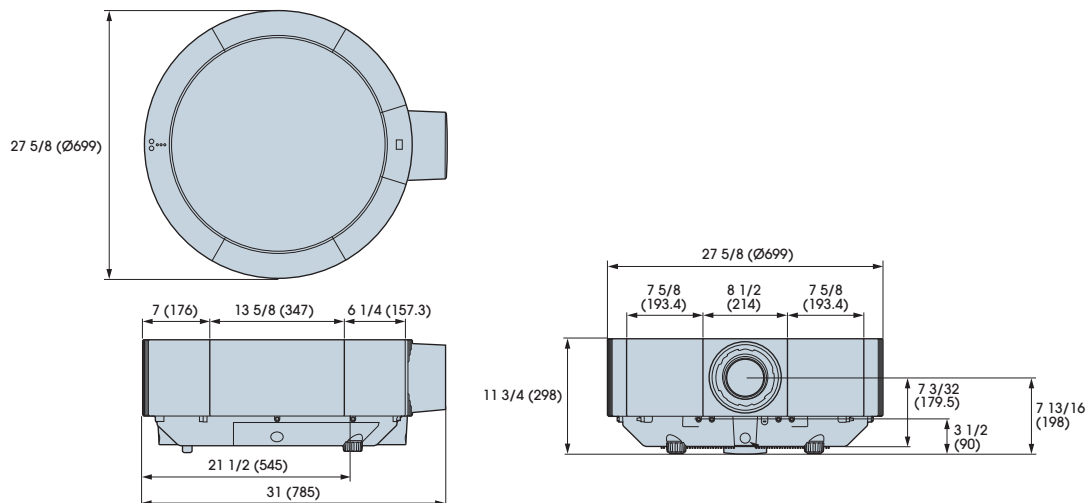

Unit: inches (mm)

Installation Diagrams

(When using the VPL-FH300L or VPL-FW300L with the optional VPLL-Z4019 lens)

Floor Installation

VPL-FH300L

Screen size*		40	60	80	100	120	150	180	200	250	300	400	500	600	
a	min	(inches) (65 3/8)	(100 7/8)	(135 7/8)	(171)	(206 3/8)	(259 1/8)	(311 7/8)	(347)	(435 1/8)	(523)	(699)	(875)	(1051)	
	mm	1660	2560	3450	4340	5240	6580	7920	8810	11050	13280	17750	22220	26690	
max	(inches)	(84 3/4)	(129 1/4)	(174 1/8)	(218 5/8)	(263 1/2)	(330 3/8)	(397 3/8)	(441 7/8)	(553 3/8)	(665 1/2)	(888 3/4)	(1112)	(1335 1/4)	
	mm	2150	3280	4420	5550	6690	8390	10090	11220	14060	16900	22570	28240	33910	
b	min	(inches) (x-10 3/8)	(x-15 1/2)	(x-20 5/8)	(x-25 3/4)	(x-30 7/8)	(x-38 1/2)	(x-46 1/4)	(x-51 3/8)	(x-64 1/4)	(x-77)	(x-102 3/4)	(x-128 3/8)	(x-154)	
	mm	x-261	x-391	x-521	x-652	x-782	x-977	x-1173	x-1303	x-1629	x-1955	x-2607	x-3258	x-3910	
c	min	mm	x-459	x-589	x-719	x-850	x-980	x-1175	x-1371	x-1501	x-1827	x-2153	x-2805	x-3456	x-4108
	(inches)	(x-18 1/8)	(x-23 1/4)	(x-28 3/8)	(x-33 1/2)	(x-38 5/8)	(x-46 3/8)	(x-54)	(x-59 1/8)	(x-72)	(x-84 7/8)	(x-110 1/2)	(x-136 1/8)	(x-161 3/4)	
max	(inches)							(x-7 7/8)							
	mm							x-198							

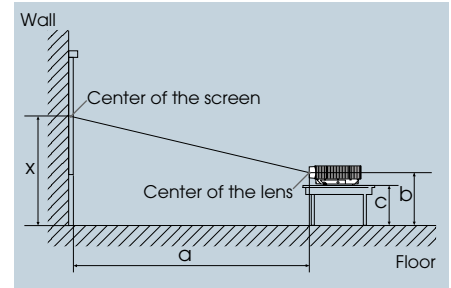

- a: Distance between the screen and the center of the lens
- b: Distance between the floor and the center of the lens
- c: Distance between the floor and the center of the lens
- x: Distance between the floor and the center of the screen (free)

VPL-FW300L

Screen size*		40	60	80	100	120	150	180	200	250	300	400	500	600
a	min	(inches) (63 7/8)	(98 1/8)	(132 3/8)	(166 5/8)	(200 7/8)	(252 1/2)	(304)	(338 1/4)	(424 1/8)	(509 5/8)	(681 1/4)	(852 7/8)	(1024 1/8)
	mm	1620	2490	3360	4230	5100	6410	7720	8590	10770	12940	17300	21660	260160
max	(inches)	(82 3/8)	(126)	(169 3/8)	(213 1/8)	(256 3/4)	(322 1/8)	(387 1/2)	(430 7/8)	(539 7/8)	(648 5/8)	(866 1/4)	(1084)	(1302 1/4)
	mm	2090	3200	4300	5410	6520	8180	9840	10940	13710	16470	22000	27530	33070
b	min	(inches) (x-11 1/8)	(x-16 3/4)	(x-22 1/4)	(x-27 7/8)	(x-33 3/8)	(x-41 3/4)	(x-50 1/8)	(x-55 5/8)	(x-69 1/2)	(x-83 1/2)	(x-111 1/4)	(x-139)	(x-166 7/8)
	mm	x-282	x-424	x-565	x-706	x-847	x-1059	x-1271	x-1412	x-1765	x-2118	x-2824	x-3530	x-4236
c	min	(inches) (x-19)	(x-24 1/2)	(x-30 1/8)	(x-35 5/8)	(x-41 1/4)	(x-49 1/2)	(x-57 7/8)	(x-63 1/2)	(x-77 3/8)	(x-91 1/4)	(x-119)	(x-146 7/8)	(x-174 5/8)
	mm	x-480	x-622	x-763	x-904	x-1045	x-1257	x-1469	x-1610	x-1963	x-2316	x-3022	x-3728	x-4434
max	(inches)							(x-7 7/8)						
	mm							x-198						

* Viewable area measured diagonally.

Ceiling Mount Installation

VPL-FH300L

Screen size*		40	60	80	100	120	150	180	200	250	300	400	500	600
a'	min	(inches) (77 3/8)	(106 3/4)	(141 3/4)	(176 7/8)	(212 1/4)	(265)	(317 7/8)	(352 7/8)	(441)	(528 7/8)	(704 7/8)	(880 7/8)	(1056 7/8)
	mm	1810	2710	3600	4490	5390	6730	8070	8690	11200	13430	17900	22370	26840
max	(inches)	(90 1/4)	(135 1/8)	(179 5/8)	(224 1/2)	(269)	(335 7/8)	(403 1/4)	(447 3/4)	(559 5/8)	(671)	(894 1/4)	(1117 7/8)	(1341 1/8)
	mm	2290	3430	4560	5700	6830	8530	10240	11370	14210	17040	22710	28390	34060
b	min	(inches)						c+7 1/8						
	mm							c+180						
max	(inches)							c+7 1/2						
	mm							c+188						
c	Using PSS-630	13 7/8, 15, 16 1/4, 17 3/8, 18 5/8, 19 3/4 inches (350, 380, 410, 440, 470, 500 mm)												
	Using PSS-630 and PSS-630P (x1)	24 7/8, 26, 27 1/4, 28 3/8, 29 5/8, 30 3/4 inches (630, 660, 690, 720, 750, 780 mm)												
	Using PSS-630 and PSS-630P (x2)	35 7/8, 37 1/8, 38 1/4, 39 3/8, 40 5/8, 41 3/4 inches (910, 940, 970, 1,000, 1,030, 1,060 mm)												
	Using PSS-630 and PSS-630P (x3)	47, 48 1/8, 49 1/4, 50 1/2, 51 5/8, 52 7/8 inches (1,190, 1,220, 1,250, 1,280, 1,310, 1,340 mm)												
	x	min	(inches)						c+7 1/8					
max	mm							c+180						
	(inches)	(c+18 1/8)	(c+23 1/4)	(c+28 3/8)	(c+33 1/2)	(c+38 5/8)	(c+46 3/8)	(c+54)	(c+59 1/8)	(c+72)	(c+84 7/8)	(c+110 1/2)	(c+136 1/8)	(c+161 3/4)
mm	c+459	c+589	c+719	c+850	c+980	c+1175	c+1371	c+1501	c+1827	c+2153	c+2805	c+3456	c+4108	

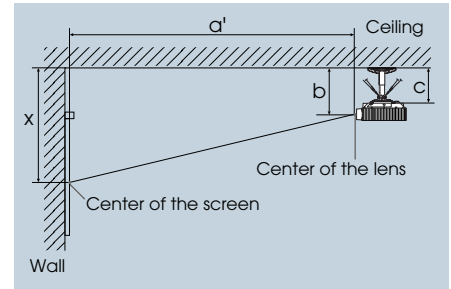

- a': Distance between the screen and the center of the lens
- b: Distance between the ceiling and the center of the lens
- c: Distance between the ceiling and the surface of suspension support (PSS-630 recommended)
- x: Distance between the floor and the center of the screen

VPL-FW300L

Screen size*		40	60	80	100	120	150	180	200	250	300	400	500	600
a'	min	(inches) (69 3/4)	(104)	(138 1/4)	(172 1/2)	(206 3/4)	(258 3/8)	(310)	(344 1/4)	(430)	(515 7/8)	(687 1/8)	(858 7/8)	(1030 1/2)
	mm	1770	2640	3510	4380	5250	6560	7870	8740	10920	13100	17450	21810	26170
max	(inches)	(88 1/4)	(131 5/8)	(175 1/4)	(219)	(262 1/4)	(327 5/8)	(393)	(436 3/4)	(545 3/8)	(654 1/2)	(872 1/4)	(1090)	(1307 3/4)
	mm	2240	3340	4450	5560	6660	8320	9980	11090	13850	16620	22150	27680	33210
b	min	(inches)						c+7 1/8						
	mm							c+180						
max	(inches)							c+7 1/2						
	mm							c+188						
c	Using PSS-630	13 7/8, 15, 16 1/4, 17 3/8, 18 5/8, 19 3/4 inches (350, 380, 410, 440, 470, 500 mm)												
	Using PSS-630 and PSS-630P (x1)	24 7/8, 26, 27 1/4, 28 3/8, 29 5/8, 30 3/4 inches (630, 660, 690, 720, 750, 780 mm)												
	Using PSS-630 and PSS-630P (x2)	35 7/8, 37 1/8, 38 1/4, 39 3/8, 40 5/8, 41 3/4 inches (910, 940, 970, 1,000, 1,030, 1,060 mm)												
	Using PSS-630 and PSS-630P (x3)	47, 48 1/8, 49 1/4, 50 1/2, 51 5/8, 52 7/8 inches (1,190, 1,220, 1,250, 1,280, 1,310, 1,340 mm)												
	x	min	(inches)						c+7 1/8					
max	mm							c+180						
	(inches)	(c+19)	(c+24 1/2)	(c+30 1/8)	(c+35 5/8)	(c+41 1/4)	(c+49 1/2)	(c+57 7/8)	(c+63 1/2)	(c+77 3/8)	(c+91 1/4)	(c+119)	(c+146 7/8)	(c+174 5/8)
mm	c+480	c+622	c+763	c+904	c+1045	c+1257	c+1469	c+1610	c+1963	c+2316	c+3022	c+3728	c+4434	

* Viewable area measured diagonally.

For both floor and ceiling mount installations, images can be shifted horizontally by +/-10% of the screen width.

Specifications

	VPL-FH300L	VPL-FW300L
Optical		
Projection system	3 LCD panels, 1 lens projection system	
LCD panel	1.2-inch TFT LCD panel, 6,635,520 (2048 x 1080 x 3) pixels	1.2-inch TFT LCD panel, 3,278,400 (1366 x 800 x3) pixels
Projection lens	Not supplied, refer to "Optional Lens"	
Lamp	275 W ultra high pressure lamp x 2	
Screen coverage	40 to 600 inches* (with lenses except VPLL-Z4045), 60 to 600 inches* (with VPLL-Z4045)	
Light output (with VPLL-Z4019)	6000 lumens (lamp mode high), 4800 lumens (lamp mode standard)	7000 lumens (lamp mode high), 5600 lumens (lamp mode standard)
Signals		
Color system	NTSC3.58, PAL, SECAM, NTSC4.43, PAL-M, PAL-N, PAL60 (automatically/manually selected)	
Resolution	Video: 750 TV lines, RGB: 2048 x 1080 pixels	Video: 750 TV lines, RGB: 1366 x 800 pixels
Acceptable computer signals	fH: 19 to 92 kHz, fV: 24 to 92 Hz Maximum input signal resolution (analog): up to UXGA (fV: 60 Hz) Maximum input signal resolution (digital): up to 2K x 1K (fV: 24 Hz)**	
Acceptable video signals	Composite Video, Y/C Video, 15 kHz RGB, Component 50/60 Hz, Progressive Component 50/60Hz, DTV (480/60i, 575/50i, 480/60p, 575/50p, 720/60p, 720/50p, 1080/60i, 1080/50i, 1080/60p, 1080/50p, 1080/24p, 1080/30p)	
General		
Dimensions (W x H x D)	27 5/8 x 11 3/4 x 31 inches (699 x 298 x 785 mm) (including projection parts)	
Weight	Approx. 67 lb 4 oz (30.5 kg)	
Power requirements	AC 100 to 240 V, 8.2 to 3.4 A, 50/60 Hz	
Power consumption	Max.:820 W, standby mode: 30 W (standard mode)/0.5 W (low mode)	
Operating temperature	32 to 95 °F (0 to 35 °C)	
Operating humidity	35 to 85% (no condensation)	
Storage temperature	-4 to 140 °F (-20 to 60 °C)	
Storage humidity	10 to 90%	
Inputs/Outputs		
Video In	Composite Video	BNC
	S Video	Y/C, mini DIN 4-pin
Video Out	Composite Video	BNC (Loop-through output)
	S Video	Y/C, mini DIN 4-pin (Loop-through output)
Input A	RGB	Analog RGB: HD D-sub 15-pin (female)
Input B	RGB	Analog RGB: HD D-sub 15-pin (female)
Input C	RGB/Component	Analog RGB/Component: 5 BNC
Input D	RGB/Component	Digital RGB/Y CB (PB) CR (PR): HDMI (HDCP)
Input E		Open for optional board
Input F	Input F	RJ-45: 10BASE-T/100BASE-TX
Output ***	RGB	Analog RGB: HD D-sub 15-pin (female)
Remote	RS-232C	D-sub 9 pin (female)
	Control S IN	Control S in/plug in power: stereo mini jack
Supplied accessories		
	Remote Commander (1), Size AA (R6) batteries (2) for Remote Commander, Lens hole cover (1), Security label (1), CD-ROM (Operating instructions, Application software) (1), Quick reference manual (1), Safety regulations (1) , Dust cover (1), AC connector cover (1), HDMI connector cover (1), AC power cord (1), Warranty card (1)	

* Viewable area measured diagonally.

** When a 2K x 1K (2048 x 1080) signal is input, information of a vertical one line at both ends is not displayed. The signal being displayed is not native. 2K x 1K equivalent.

*** RGB signals can be output from input A, input B, and input C connectors.



- Halogenated flame retardants are not used in cabinets or printed wiring boards.
- Standby power consumption: 0.5 W (in low mode).

SONY

Sony Electronics Inc.
1 Sony Drive
Park Ridge, NJ 07656
www.sony.com/professional

DI-0148 (MK10465V1)

©2008 Sony Electronics Inc. All rights reserved.
Reproduction in whole or in part without written permission is prohibited.
Features and specifications are subject to change without notice.
All non-metric weights and measurements are approximate. Projected images in this brochure are simulated. Sony, BrightEra, Remote Commander, HDCAM, and XDCAM are trademarks of Sony. HDMI, the HDMI logo, and High-Definition Multimedia Interface are trademarks or registered trademarks of HDMI Licensing LLC. Microsoft, PowerPoint, Windows, and DirectX are trademarks of Microsoft Corporation. Intel and Pentium are trademarks of Intel Corporation.

Printed in USA (2/08)