

Sony NXCAM Product Workflows

in Sony Vegas Pro9

Table of Contents

1- Introduction	4
HXR-NX5U and the NXCAM™ Product Line	4
Flexible Selection of Recording Media	4
Dual Memory Card Slots	4
HYBRID Recording with the Sony HXR-FMU128	4
Flexible Recording Format Selection	6
Recording Time	7
NXCAM Folder Structure and File Names	7
2- Workflow Overview	9
Using the Sony Content Management Utility	9
Content Management Utility Overview	10
Transferring NXCAM Media to a Local HDD via the CMU	11
Registering Existing NXCAM Media in the CMU	12
Archiving Original NXCAM Media	13
Archiving Example	13
Importing Clips From Archived Folders	14
3- Key workflow features in Vegas® Pro9	16
Supported NXCAM Recording Modes	16
System Requirements	16
Connections	16
Creating a Vegas Pro Project	17
Importing NXCAM Media Files	18
Method 1: Dragging to Vegas Software Bin	18
Method 2: Using Vegas Import Media	19
Using Vegas Pro9 Special Import Module	20
Adding Clips to the Timeline	21

1 - Introduction

2 - Workflow Overview

3 - Key Workflow Features
in Vegas Pro9

4 - Project Output

5 - Notes

4- Project Output22

 Blu-ray Disc™23

 High Quality Movie File24

 HDV™ Video Tape25

 Output to an HD Recorder via HD-SDI25

5- Notes26

1 - Introduction

The HXR-NX5U is Sony's first NXCAM branded camcorder. This document explains how to edit video recorded by this camcorder using Sony Vegas Pro9.

HXR-NX5U and the NXCAM Product Line

NXCAM is Sony's newest product line designed for professionals. NXCAM provides powerful features for professional video production, such as HD-SDI output, flexible media selection, and stunning AVCHD picture quality.

The HXR-NX5U camcorder incorporates cutting-edge technologies, such as G Lens, an Exmor™ CMOS sensor, built-in GPS receiver, and a new Active SteadyShot® mode.

Flexible Selection of Recording Media

Various recording media are available in the HXR-NX5U:

- Memory Stick PRO Duo(Mark2)™ media, Memory Stick PRO-HG Duo™ media, Memory Stick PRO-HG Duo HX™ media*
- SD/SDHC Memory Card**
- Flash Memory Unit (Sony HXR-FMU128)

*Compatible "Memory Stick" type: For AVCHD recording / Capacity: more than 1GB, For standard definition recording / Capacity: more than 512MB

**Recommended Speed Class For AVCHD recording / Class 4 or higher, For standard definition recording / Class 2 or higher

Dual Memory Card Slots

The HXR-NX5U has two memory card media slots for recording. Use of Sony's Memory Stick PRO Duo™, and Memory Stick PRO Duo HG™, are recommended media cards.

The HXR-NX5U records to a single memory card slot at a time. With two memory cards installed, the camcorder provides continuous, seamless recording of long scenes, and maximizes the utilization of each card's storage capacity.

As the card in Slot A reaches its capacity, recording is automatically switched to the card in Slot B. The card in Slot A may then be removed and replaced. When the card in Slot B fills to capacity, another seamless switch back to Slot A occurs.

This unique dual slot configuration provides continuous recording without any breaks in content or time code.

Prior to editing, clips that span one or more memory cards may be merged using the Sony Content Management Utility (CMU), a software accessory supplied with the camcorder.

HYBRID Recording with the Sony HXR-FMU128

The Sony HXR-FMU128, an optional flash memory recording unit specially designed for the HXR-NX5U, mounts to the camcorder without the need for any external cabling. Built around a 128 GB solid state flash memory drive, the HXR-FMU128 offers significantly longer recording time than a single memory card.

When the HXR-FMU128 is used in conjunction with memory cards, Sony's unique HYBRID recording capability is enabled, allowing a combination of HD and SD resolutions to be recorded simultaneously. The operator is free to choose which resolution is recorded on each media type, and may even set the camcorder to record to both media types simultaneously.

There are many benefits to HYBRID recording, including:

- Edit system ingest time for HD files stored on the HXR-FMU128 is typically faster than from memory cards.
- HD files simultaneously recorded on memory cards provide a time and cost-effective method of archiving.
- SD files may be used for quick preview on a laptop or for SD deliverables, such as web-based movies.

Note: Recording SD simultaneously to both media types is not supported.

Important: The filenames of corresponding HD and SD clips are different.

Flexible Recording Format Selection

HD (AVCHD)

Video Compression

- **FX mode** (1920x1080 or 1280x720, 21 Mbps*)
- **FH mode** (1920x1080 or 1280x720, 16 Mbps)
- **HQ mode** (1440x1080 or 1280x720, 9 Mbps)
- **LP mode** (1440x1080 or 1280x720, 5 Mbps)

*Including audio and ancillary data the total data rate is 24Mbps

Frame Rate, 60i models

- 1080/60i (59.94i)
- 1080/30p (29.97p)
- 1080/24p (23.98p)
- 720/60p (59.94p)

Frame Rate, 50i models

- 1080/50i
- 1080/25p
- 720/50p

Audio

- Linear PCM (uncompressed)
- AC-3 (compressed)

SD (MPEG2)

Video Compression

- MPEG2 Program Stream, approx. 9Mbps
- NTSC (720x480) or PAL (720x576)
- 4:3 or 16:9 selectable

Frame Rate, 60i models

- 480/60i (59.94i)
- 480/30p scan: 30p scanned image is recorded as 60i
- 480/24p scan: 24p scanned image is recorded as 60i with 2-3 pulldown.

Frame Rate, 50i models

- 576/50i
- 576/25p scan: 25p scanned image is recorded as 50i

Audio

- AC-3 only

Recording Time

Refer to the charts below to determine the approximate maximum recording time for each media type and quality setting.

HD MOVIE w/Linear PCM 2ch	AVCHD (FX)	AVCHD (FH)	AVCHD (HQ)	AVCHD (LP)
8GB Memory Stick PRO Duo media	40 min	55 min	95 min	150 min
16GB Memory Stick PRO Duo media	85 min	110 min	190 min	300 min
32GB Memory Stick PRO Duo media	170 min	225 min	385 min	605 min
HXR-FMU128 (128GB)	700 min	930 min	1570 min	2490 min

SD Movie w/Dolby Digital 2ch	MPEG2-SD 9M (HQ)
8GB Memory Stick Pro Duo media	115 min
16GB Memory Stick Pro Duo media	235 min
32GB Memory Stick Pro Duo media	475 min
HXR-FMU128 (128GB)	1960 min

NXCAM Folder Structure and File Names

Below is a brief overview of the folder structure and file naming conventions recorded on memory cards or the optional HXR-FMU128 flash memory recorder.

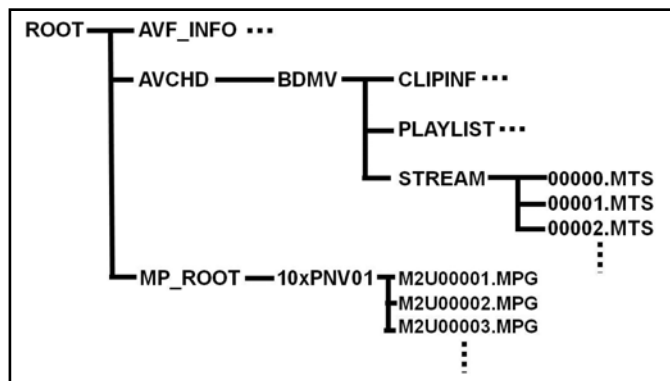

.MTS file

This is the high quality AVCHD video stream data. During long recordings, the clip is automatically divided (spanned) into 2GB segments. Spanned files are seamlessly merged while transferring to a computer via the Sony Content Management Utility (CMU) for NXCAM format.

.MPG file

This is the SD quality MPEG2 file. During long recordings, the clip is automatically divided (spanned) into 2GB segments.

AVF_INFO, MEMSICK.IND

These folders/files are administrative in nature.

Important: Do not move or copy individual clips via Windows Explorer® or the Macintosh Finder, as this will result in unusable media on the target drive.

For copying individual clips to hard disk, use the Sony Content Management Utility (CMU).

Windows Explorer or the Macintosh Finder may be used to do an archive of the entire contents of either a memory card or HXR-FMU128, as long as all ancillary and hidden files are included in the transfer.

When archiving on a Windows system (or a Windows boot on a Macintosh computer), always select “Show hidden files and folders” in the Folder Options “View” tab, as shown below.

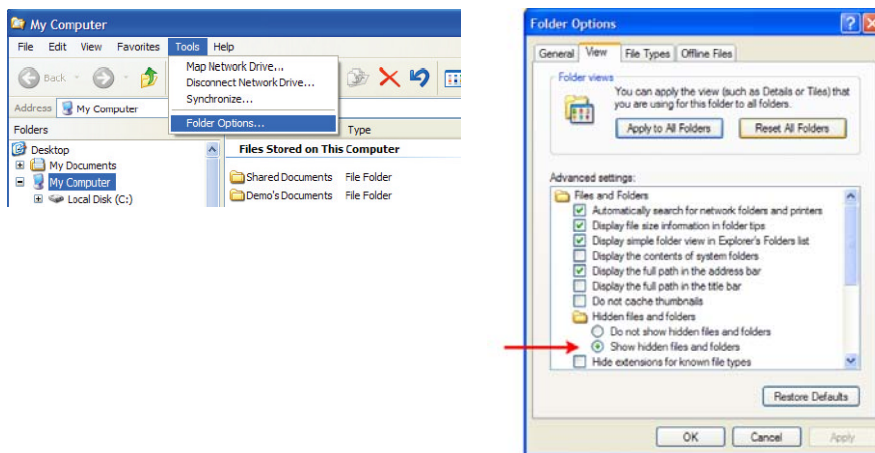

2- WORKFLOW OVERVIEW

Using the Sony Content Management Utility

The Sony HXR-NX5U includes the Sony Content Management Utility (CMU), a Windows-based software application for importing, previewing, and copying clips from NXCAM media.

A typical NXCAM/CMU workflow is as follows:

- 1 – Transfer clips from a memory card or HXR-FMU128 to local hard disc storage via the CMU.
- 2 – Use the CMU to browse and select the necessary clips.
- 3 – Import the selected clips to the NLE project bin.
- 4 – Begin editing.

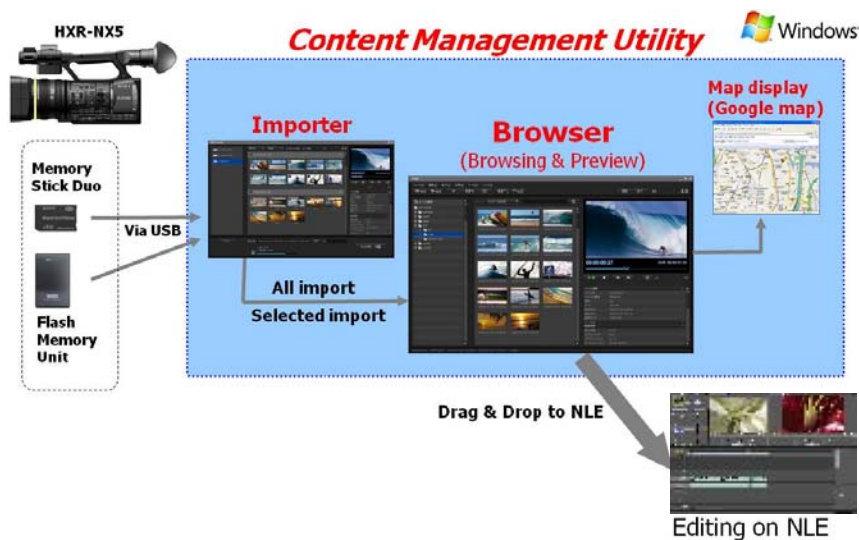

Note that the workflows outlined here represent just a few examples of how to work with the AVCHD format, and that workflows can vary based on the project and/or installation.

For more detailed information on any of the software or hardware mentioned in this document, please refer to the manufacturer-supplied Operations Guide for the associated product.

Content Management Utility Overview

Below is a brief overview of the CMU Browser window.

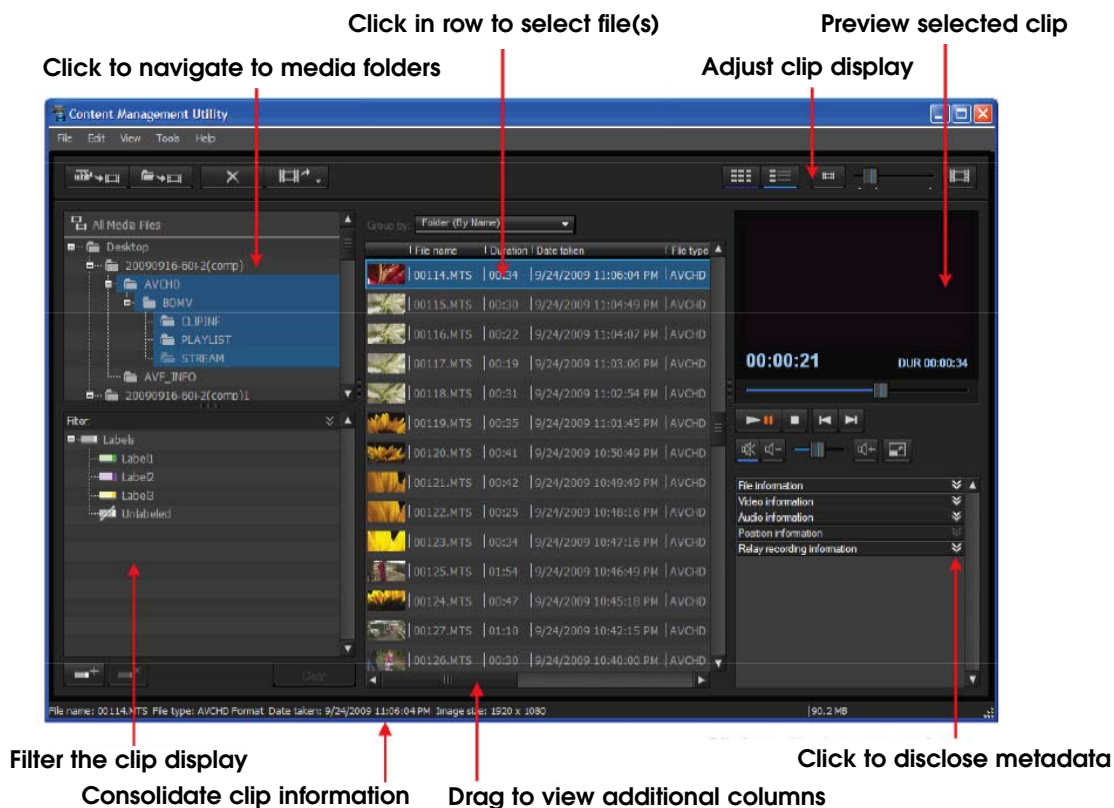

Some of the key workflow features of the CMU are:

- Transferring of clips from memory card or HXR-FMU128 to local hard disc storage.
- Combining FAT32 spanned clips into one single file.
- Combining clips that span two or more memory cards.
- Registering of any folders on the local hard drive that contain AVCHD or MPEG-SD media files.
- Clip browsing.
- Browsing of media metadata, such as date, recording mode, and GPS data.
- Indication of shooting location on Google Maps™, using the embedded GPS data.
- Extraction of the GPS data as NMEA standard GPS format.

Transferring NXCAM Media to a Local HDD via the CMU

In most cases, NXCAM clips should be transferred to local hard disc storage prior to editing. The CMU Importer module is used for this operation.

- 1 – Launch the CMU application. The CMU Browser window will open.
- 2 – Click the **Import Media Files** button, located at the top left of the CMU Browser window. The CMU Importer window will open.
- 3 – Select the connected memory card or HXR-FMU128 drive.
- 4 – Select the clips to be transferred.
- 5 – Specify the destination folder on the PC hard drive.
- 6 – Click the **Import** button.

Note: Clips must be transferred in their entirety. There is no trim function for partial file transfers.

The imported clips from either card media or HXR-FMU128 are stored in the specified destination folder as below:

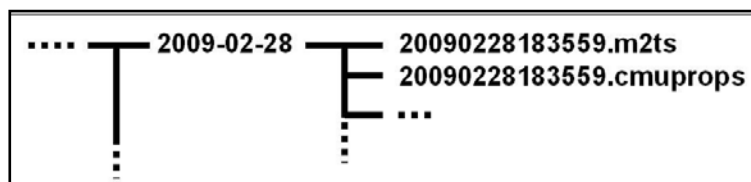

.m2ts

The file extension "MTS" of the camera-original file is replaced as "m2ts". **This operation has no effect on the picture or sound quality.**

.cmuprops

This is a property file for each media file.

Important: The above procedure may be applied selectively, or to the entire contents of an NXCAM volume. Performing a full archive of the original card media, in addition to the above operation, is recommended.

Registering Existing NXCAM Media in the CMU

NXCAM video files contained on local hard disc storage must be registered in the CMU prior to browsing. To register a folder of videos, do the following:

- 1 – Launch the CMU application.
- 2 – Click the **Register Folders to View** button, located at the top left of the CMU Browser window. The Register window will open.

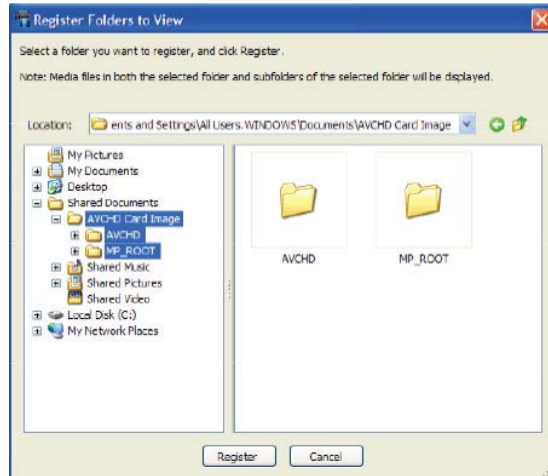

- 3 – Navigate to the folder that you want to register.
- 4 – Click the **Register** button.

Important: The procedure above is only applicable to .MTS files previously stored to the computer hard drive(s). The CMU mounts NXCAM card media and the HXR-FMU128 automatically.

Archiving Original NXCAM Media

In a typical workflow, the CMU is used to copy clip data from memory cards to a user-specified destination folder on a local hard drive. Spanned clips are automatically merged as part of this process. These transferred clips may then be imported to the NLE project.

As part of the transfer process from card to hard disc, the original folder structure and some metafiles created by the NXCAM camcorder are lost. Therefore, **performing an archive of all camera-original material is highly recommended.**

Copying individual clips via Windows Explorer or the Macintosh Finder will result in unusable media on the target drive. When archiving the contents of either a memory card or HXR-FMU128, always copy the entire contents of the volume, including all ancillary files.

Important: When archiving on a Windows system (or on a Windows boot on a Macintosh® computer), always select “show hidden files and folders” in the Windows folder options. Then copy all shown folder/files to a storage drive, maintaining the original folder structure.

Archiving Example

When working with multiple memory cards and/or cameras, an organized archival workflow should be employed. Below is a typical workflow for archiving NXCAM media:

- 1 – After shooting with a memory card, provide a unique physical label, such as “091231-CAM1-1”, which is the date, camera number, and card number.
- 2 – Load the memory card in a card reader connected to your computer.
- 3 – When using the Windows OS, always choose the “Show hidden files and folders” option located in the Folder Options pane (**Start > Control Panel > Folder Options > View**).
- 4 – Make a new folder in the storage drive. Rename the folder to match the project name, such as “Holiday Event.”
- 5 – Inside the above folder, create a child folder. Rename that folder to match the label on the memory card, in this example: “091231-CAM1-1”.
- 6 – Copy all data including the hidden folders/files from the memory card to the child folder.
- 7 – Repeat the above for all subsequent cards (omit Step 4), providing unique label/folder names for each memory card. For example, the second card from the same camera could be labeled “091231-CAM1-2”.

Note: The same procedure should be followed when using the HXR-FMU128

Importing Clips From Archived Folders

Archived card images must be mounted as virtual external drives by the CMU prior to the import of clips to the NLE.

Importing clips from a full-card archive on hard disc involves first mounting the card image as a virtual external drives. This requires the installation of the freeware application “**Folder Drives**”, available as a free download from <http://camtech2000.net>.

To assign a Windows drive letter to a folder on your hard disc:

- 1 – Double click on the **Folder Drives** Desktop icon. The window below will open.



- 2 – In the **Select Folder** field, navigate to the folder containing the media.
- 3 – In the **Available Drive Letters** field, choose a Drive Letter from the list presented.
- 4 - Click **Create Drive**. The folder will be added to the Virtual Drive list, as below:



- 5 – In the CMU, click the Import Media Files button. The virtually mounted folders will appear as external drives in the CMU importer window.

New Virtual Volume from “Folder Drives”

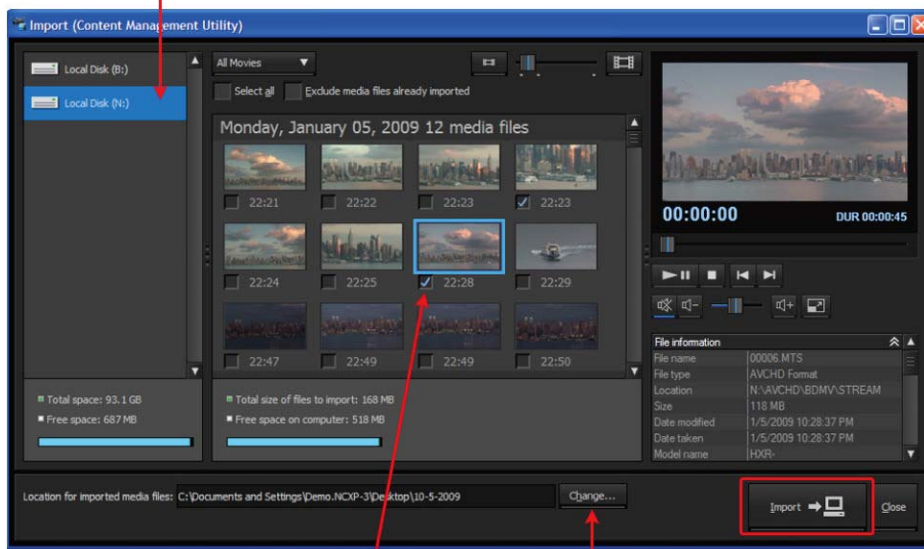

Click in box to select clip for importing Click to set a location for imported media

- 6 – Select a volume to browse.
- 7 – Checkmark the files to be imported.
- 8 – Set a location for the imported files.
- 9 – Click the **Import to PC** button.

3 – Key workflow features in Vegas Pro9

Supported NXCAM Recording Modes

The following NXCAM recording modes are supported:

- Support for 1080 50i/60i/24p/25p/30p, 720/50p/60p

System Requirements

- Microsoft Windows® XP 32-bit SP2 (SP3 recommended) or Windows Vista™ 32-bit or 64-bit (SP1 recommended)
- USB 2.0 connection
- Vegas Pro9 application software. (For more details about Vegas Pro9, please visit the Sony Creative Software website.)
- CMU for NXCAM (supplied with HXR-NX5U and HXR-FMU128)
- NXCAM compatible memory cards
- HXR-FMU128 (optional)

Connections

- When using memory cards, connect a generic USB 2.0 memory card reader to your computer. The file transfer speed may vary based on the card reader's specifications and connection method. A direct connection (not through a USB hub) is recommended.
- When using the Sony HXR-FMU128, connect via a USB 2.0 compatible cable. As with the memory card reader, a direct connection to the computer is recommended.

Creating a Vegas Pro Project

1 – To create a new project, select **File > New** (or press **CTRL + N**).

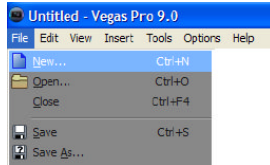

2 – In the **New Project** window, choose a template that closely matches the majority of your material.

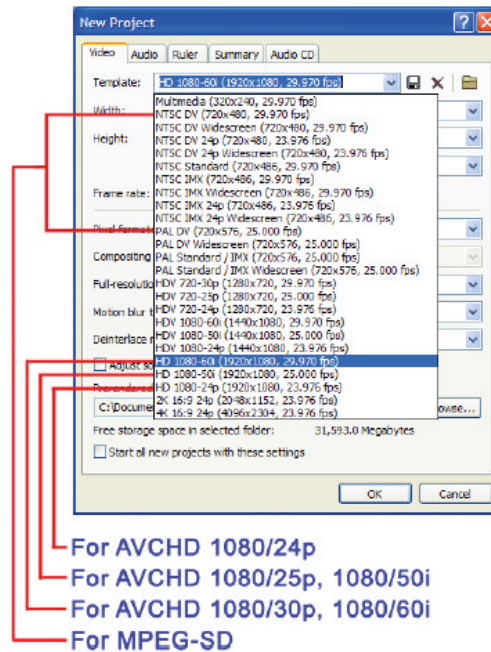
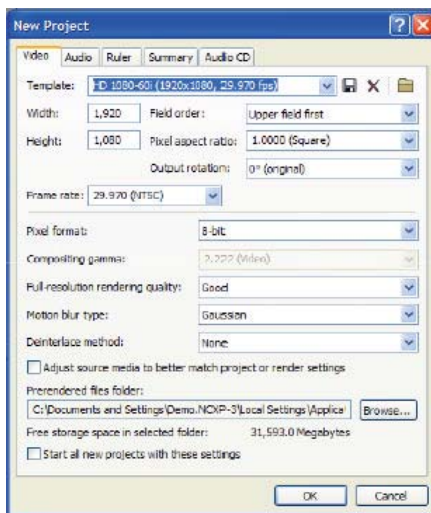

Important: For AVCH 1080/30p and AVCHD1080/25p, always set the Field Order as "Progressive".

3 – Click **OK**.

4 – Select **File > Save** (or **CTRL + S**) to name the project and save it to the computer hard drive.

Importing NXCAM Media Files

Prior to importing media files into a Vegas Pro project, use the CMU application to transfer the media to the local hard drive(s). The import to the Vegas project may then be accomplished in one of the following ways:

Method 1: Dragging to Vegas Software Bin

Use the CMU or Windows Explorer® to navigate to the transferred file location on the HDD.

- 1 – Select the file(s) in the CMU or Windows Explorer to import to the Vegas project.
- 2 – Drag the files to Vegas Project Media Bin.

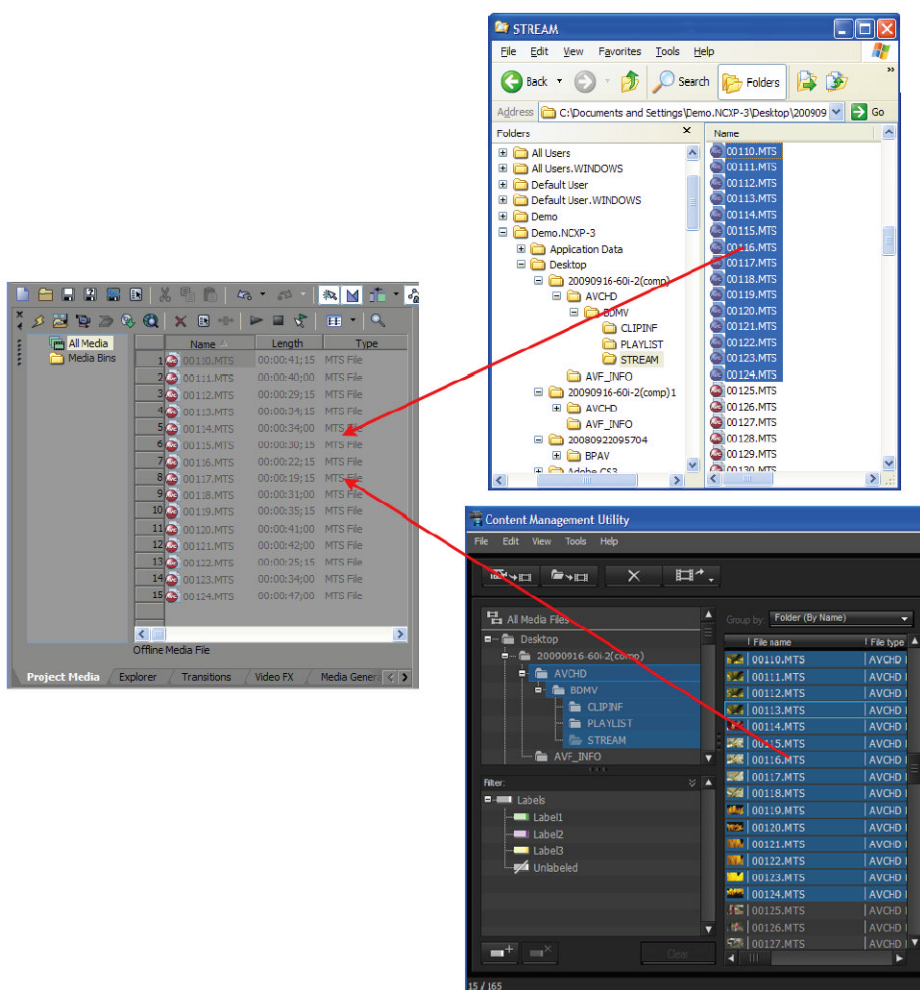

Method 2: Using Vegas Import Media

- 1 – Select **File > Import > Media**.
- 2 – Navigate to the folder where the transferred files are stored.

Note: Vegas Pro automatically filters-out the metadata files from the list of clips.

- 3 – Do one of the following:
 - To import all clips, select all of the MTS (or m2ts) files.
 - Prepare for a selective import by highlighting specific clips.
- 4 – Select **Open** (or press Enter).

Note: Thumbnail View is not supported for MTS (or m2ts) files in Windows XP/Vista.

Using Vegas Pro 9 Special Import Module

Vegas Pro 9 employs a special import module expressly for ingest of NXCAM media from either memory cards or the HXR-FMU128 without using the CMU application.

Important: Although the workflow detailed in this section is faster than one where clips are first copied to local storage via the CMU, the Special Import Module does not merge spanned clips, and these files may not function correctly in the timeline.

If a memory card or HXR-FMU128 contains spanned clips, the CMU application should be utilized to transfer the files to local drive(s), followed by the Vegas “Import > Media” workflow (as described in the previous section).

To import from a memory card or HXR-FMU128:

- 1 – Select a Bin.
- 2 – Select **View > Device Explorer**.

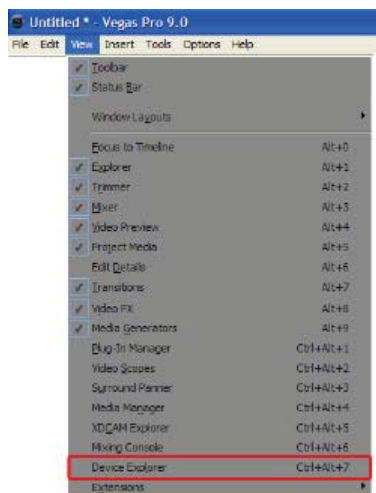

- 3 – Right-click the left pane of the Device Explorer window and choose **Browse** from the shortcut menu.
- 4 – The recorded clips are displayed on the right side of the window and clips that have not yet been imported are indicated with a new clip icon.
- 5 – Select the clips that you want to import, then click the Import button.
- 6 – The selected clips will be imported to the Project Media window.

For more information about the Device Explorer, please refer to the operational manual of Vegas Pro 9.

Adding Clips to the Timeline

There are a variety of methods for placing clips in the timeline, the easiest of which is to simply drag the clip from the Project Media tab to the Timeline, as shown below:

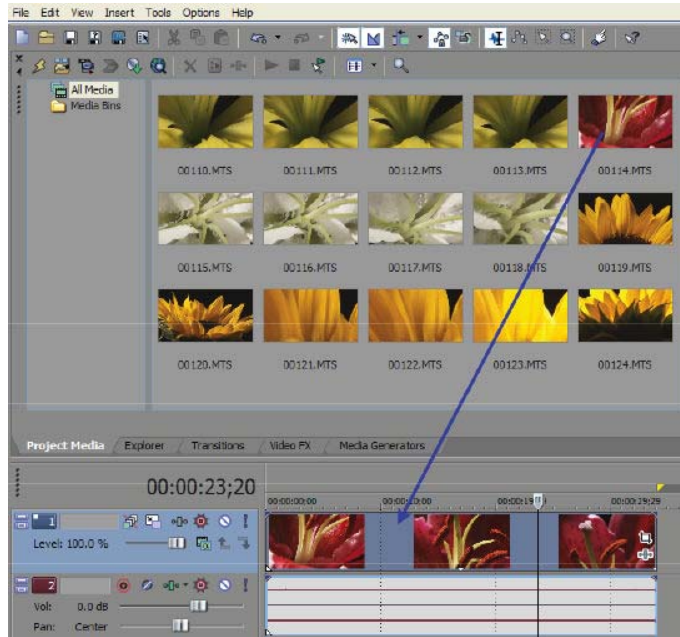

Please refer to the Vegas Pro9 Operations Guide for more detailed information on editing operations.

4 – Project Output

The finished project may be output in a variety of ways.

- To Blu-ray Disc
- To a high quality movie file
- To an HDV video tape
- To an HD recorder via HD-SDI

A general overview of the output process for each of the above follows on the next few pages. For more detailed information, please refer to the Sony Vegas 9 Operations Guide and/or the Operations Guide for the specific output device or interface.

Blu-ray Disc

1 – Select **Tools > Burn Disc > Blu-ray Disc**.

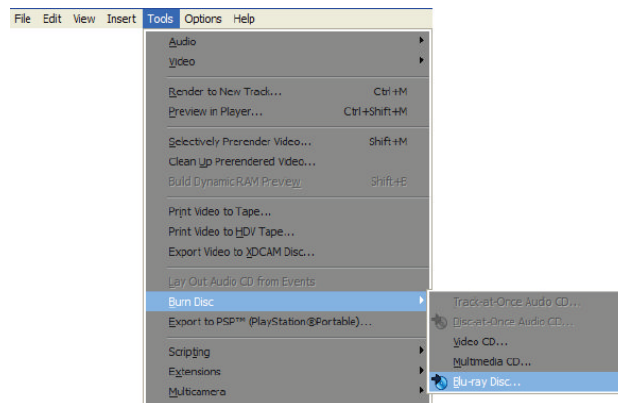

2 – Select options based on the specific project settings and desired output.

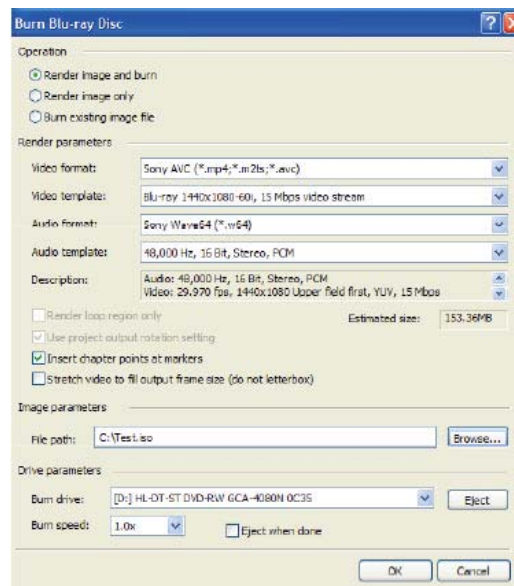

3 – Insert a blank BD-R/BD-RE disc.

4 – Click the **OK** button.

For high-level Blu-ray Disc authoring, use the bundled DVD Architect Pro application.

High Quality Movie File

Vegas Pro9 supports the creation of movie files in a variety of formats, including MXF, QuickTime®, Windows Media Video™, and MP4 for PSP® / iPod®.

1 – Select **File > Render As**.

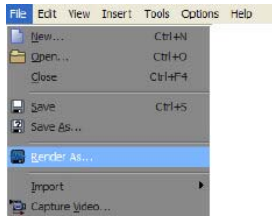

2 – Select suitable presets from the “Save as type” and “Template” drop-down lists.

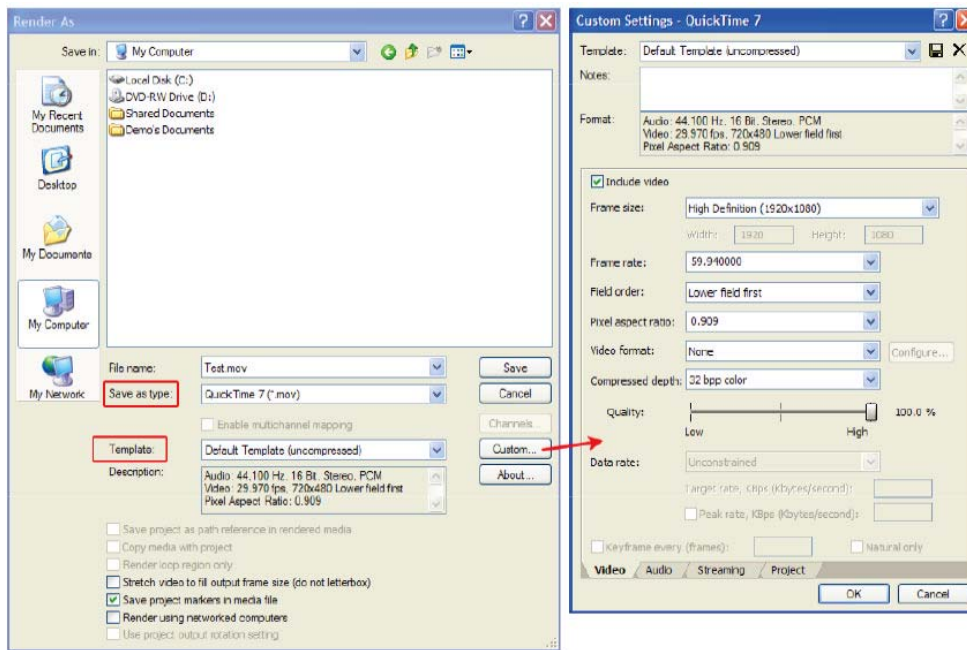

3 – Select a suitable movie template. If necessary, click the “Custom” button to create or customize an existing template.

4 – Click **Save** to make a movie file.

HDV Video Tape

- 1 – Connect an HDV deck to the computer with an i.LINK® cable.
- 2 – Select **Tools > Print Video to HDV Tape**.

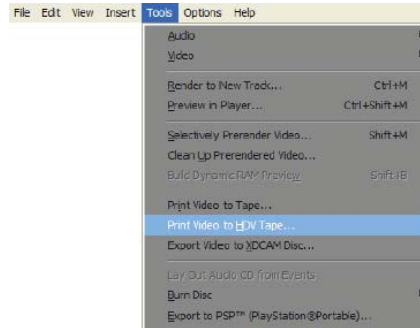

- 3 – Select options based on the specific project settings and desired output.
- 4 – Click the **Finish** button. The timeline will be output to tape.

Output to an HD Recorder via HD-SDI

Vegas Pro9 is compatible with the AJA series of HD-SDI card interface cards, supporting high quality output of the project timeline to an HD deck, such as XDCAM HD®, HDCAM® etc.

- 1 – Select **Tools > Print Video to Tape**.
- 2 – From the device drop-down list, choose “AJA video device”.
- 3 – Select options based on the specific project settings and desired output.
- 4 – Click the **Finish** button. The timeline will be output to tape.

5 – Notes

©2009 Sony Electronics Inc. All rights reserved. Reproduction in whole or in part without written permission is prohibited. Sony, NXCAM, DVCAM, XDCAM HD, HDCAM, Memory Stick PRO Duo, Memory Stick PRO Duo HG, and i.LINK are trademarks of Sony. PSP is a trademark of Sony Computer Entertainment. HDV and the HDV logo are trademarks of Sony Corporation and the Victor Company of Japan. CompactFlash is a trademark of the CompactFlash Association. Vegas and Vegas Pro are trademarks of Sony Creative Software. Windows XP and Explorer are trademarks of Microsoft Corporation. iPOD and Macintosh are trademarks of Apple Corporation. Blu-ray is a trademark of the Blu-ray Disc Association.