

Data Projector

Installation Manual for Dealers

 **WARNING**

This manual is intended for qualified service personnel only.

To reduce the risk of electric shock, fire or injury, do not perform any servicing other than that contained in the operating instructions unless you are qualified to do so.

Refer all servicing to qualified service personnel.

SRX-T110
SRX-T105

Table of Contents

Chapter 1 Overview

Precautions	4
About the Optional Accessories	5

Chapter 2 Installation and Connections

About the Display Mode	6
Projection Distance Charts	7
Before Installation	11
About the Mounting Platform	11
Positioning the Projector towards the Screen	11
Installing Lamp Houses	12
Attaching the Lens	12
Using the Optional Input Board	14
Attaching the Exhaust Duct Adaptor	15
Connecting the Projector	16
Connecting a Computer Equipped with a DVI-D Connector	16
Connecting with a Computer Equipped with an Analog RGB Connector	17
Connecting with HD-SDI Equipment	17
Connecting with Component/Video GBR Equipment	18
Connecting the AC Power Cord	18
Installing the SRX Controller	19
Setting the Projector	20
Displaying the SETTING Window	20
Owner Information	20
Date & Time	20
Network	21
Mail Report	21
PC Communication	22
SNMP	22
Profile	23

Chapter 3 Adjustments and Settings Using the SRX Controller

Displaying the Control Function Menu Window	24
PICTURE CONTROL Window	25

Board	25
Input Source	25
Signal Info (Information)	26
Signal Adjust	26
COLOR/FRAME Window	27
Board	27
Color	27
Frame Adjust	28
INSTALLATION Window.....	28
LENS CONTROL	28
ELECTRIC V SHIFT FUNCTION.....	28
SIRCS	29
IMAGE FLIP.....	29
PROGRESSIVE DISPLAY MODE	29
SQUEEZE	29
LAMP POWER.....	29
LAMP SELECT	29
TEST PATTERN	30
SERVICE Window	30
Displaying the SERVICE Window	30
WHITE BALANCE	30
REGISTRATION ADJUST	31
LAMP TIMER RESET	31
INTERPOLATION	31
COLOR SPACE CONVERTER	31
VERSION INFORMATION.....	31
Correcting the Color Characteristics (Color Space Converter) 32	
Input Signals And Adjustable/Setting Items	34

Chapter 4 Others

Lamp Life.....	35
Error Messages.....	36
Dimensions	38
External Dimensions	38
Mounting Platform Dimensions	39
Necessary Clearance for Installation and Maintenance	41
Displayed Image Size in Multiple Screen Mode	42
Index	43

Precautions

On safety

- Operate the unit on 200 – 240 V AC, 50/60 Hz (SRX-T110), or 100 – 240 V AC, 50/60 Hz (SRX-T105).
- Should any liquid or solid object fall into the cabinet, unplug the unit and have it checked by Sony dealer before operating it further.
- Unplug the unit from the wall outlet or set the power switch to the lower position if it is not to be used for several days.
- To disconnect the cord, pull it out by the plug. Never pull the cord itself.
- The wall outlet should be near the unit and easily accessible.
- The unit is not disconnected from the AC power source (mains) as long as it is connected to the wall outlet and the power switch is set to the upper position.
- Do not look into the lens while the lamp is on.
- Do not place your hand or objects near the ventilation holes. The air coming out is hot.
- Have at least four people carry and handle the projector, to avoid accidents or injury.
- Avoid using an extension cord with a low voltage limit, as it may cause short-circuiting and physical injury.
- To carry the projector, be sure to use the carrying handles. Do not hold other parts of the projector, especially the lens, nor catch your finger between the handle, floor, and the projector.
- Do not catch your finger between the unit and surface of the floor when moving the projector installed on the floor.
- Be careful not to catch your finger in the cooling fan.
- Since an intense light has come out of this projector from the front, do not stand on the front of a projector for a long time.

On installation

- Allow adequate air circulation to prevent internal heat build-up. Do not place the unit on surfaces (rugs,

blankets, etc.) or near materials (curtains, draperies) that may block the ventilation holes. Leave space of more than 100 cm (39 ³/₈ inches) between the wall and the projector. Be aware that room heat rises to the ceiling; check that the temperature near the installation location is not excessive.

- Install the projector on the floor or hang it from the ceiling. Any other installation causes a malfunction such as color irregularity or a shorten lamp life.
- Do not install the unit in a location near heat sources such as radiators or air ducts, or in a place subject to direct sunlight, excessive dust or humidity, mechanical vibration or shock.
- To avoid moisture condensation, do not install the unit in a location where the temperature may rise rapidly.

On illumination

- To obtain the best picture, the front of the screen should not be exposed to direct lighting or sunlight.
- Ceiling-mounted spot lighting is recommended. Use a cover over fluorescent lamps to avoid lowering the contrast ratio.
- Cover any windows that face the screen with opaque draperies.
- It is desirable to install the projector in a room where floor and walls are not of light-reflecting material. If the floor and walls are of reflecting material, it is recommended that the carpet and wall paper be changed to a dark color.

On preventing internal heat build-up

After turning off the power, the cooling fan runs for about 10 minutes while the STATUS LAMP indicator flashes green.

Caution

The projector is equipped with ventilation holes (intake) at the front, upper side and right side, and ventilation holes (exhaust) at the rear and upper side.

Do not block or place anything near these holes, or internal heat build-up may occur, causing picture degradation or damage to the projector.

On lamp break

Should the lamp explode, it is dangerous to be near the ventilation holes for exhaust. Keep at least 2 m (approx. 6.6 feet) (page 41) away from the projector's ventilation holes for exhaust.

Note

If someone is likely to enter the dangerous area, attach the LKRA-001 exhaust duct adaptor to the projector and install the exhaust duct.

On cleaning

- To keep the cabinet looking new, periodically clean it with a soft cloth. Stubborn stains may be removed with a cloth lightly dampened with a mild detergent solution. Never use strong solvents, such as thinner, benzene, or abrasive cleansers, since these will damage the cabinet.
- Avoid touching the lens. To remove dust on the lens, use a soft dry cloth. Do not use a damp cloth, detergent solution, or thinner.

On repacking

Save the original shipping carton and packing material; they will come in handy if you ever have to ship your unit. For maximum protection, repack your unit as it was originally packed at the factory.

On prohibiting continuous lighting

Continuously lighting the Xenon lamp for 24 hours will reduce approximately half of its lamp life. Be sure to off the lamp for an hour or more after continuously lighting for 24 hours.

To light the lamp continuously for 24 hours, it is recommended to use the lamps alternately. To use the lamps alternately, select "User-Defined" in "Single" (page 29) under "LAMP SELECT" in the INSTALLATION window and set the time.

For better image projection

Uniformity may change according to the setting environment. It is recommended to adjust the uniformity during setting and adjustment using the optional tool kit (PCAT). As uniformity may change with each use, it is recommended to adjust the uniformity regularly (approximately once every two times the lamp is replaced).

For purchase of the kit, contact your Sony dealer.

About the Optional Accessories

The projection lamps of this projector are provided as optional accessories. Install the lamp houses to the projector according to your model.

For versatile use of the projector, the optional accessories mentioned below can be used with the projector. Select to use them according to your system requirements.

For details on optional accessories, refer to the relevant operating instructions.

Lamp house

- LKRX-B110 projection lamp house for SRX-T110
- LKRX-B105 projection lamp house for SRX-T105

Lamp for replacement

- LKRX-110 projection lamp for SRX-T110
- LKRX-105 projection lamp for SRX-T105

Projection lens

- LKRL-Z115 1.48- to 1.81-times zoom lens
- LKRL-Z117 1.72- to 2.39-times zoom lens (with zoom/focus memory function)
- LKRL-Z119 1.81- to 2.94-times zoom lens (with zoom/focus memory function)
- LKRL-Z122 2.23- to 4.03-times zoom lens (with zoom/focus memory function)
- LKRL-Z140 3.81- to 7.12-times zoom lens
- LKRL-90 0.9-times fixed focus lens

Input board

- LKRI-001 analog input board
- LKRI-002 HD-SDI (4:2:2) input board
- LKRI-003 HD-SDI/DC-SDI (4:4:4) input board
- LKRI-004 DVI interface board
- LKRI-005 HDCP DVI board

Exhaust duct adaptor

LKRA-001 8-inch exhaust duct adaptor

Note

When LKRA-001 is attached, be sure to use an external fan with the specified air flow. If the projector does not exhaust enough heat, the projector becomes hot. This may cause damage to the parts in the projector.

For details on the air flow specification of the external fan, refer to the Installation Instructions of LKRA-001.

About the Display Mode

The displayed image on the screen varies with the signal input as illustrated below.

When projecting a 4096-pixel (4K × 2K) image at the maximum horizontal picture element

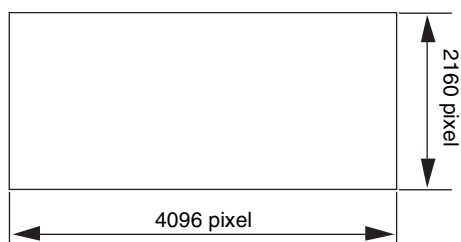

When projecting a 3840-pixel (aspect ratio 16:9) image at the maximum horizontal picture element

Black bands are displayed on the right and left sides.

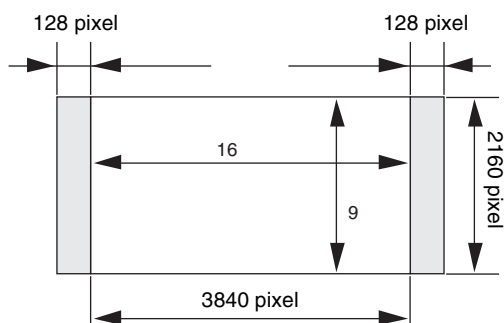

When projecting a 2880-pixel (aspect ratio 4:3) image at the maximum horizontal picture element

Black bands are displayed on the right and left sides.

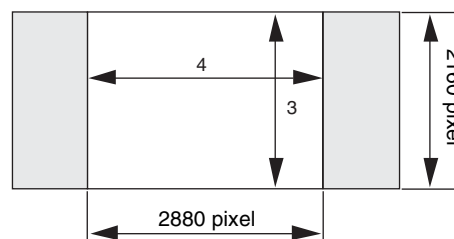

Projection Distance Charts

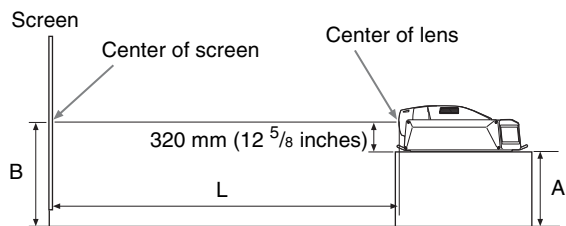

A: Distance between the floor and the feet of the projector

$$A = B - 320 \text{ mm (12 } \frac{5}{8} \text{ inches)}$$

B: Distance between the floor and the center of screen

The alphabetical characters in this section indicate the following measurements:

W: Screen width (unit: mm)

D: Screen diagonal length (unit: inch)

L(min): Minimum distance between the center of lens and screen

L(max): Maximum distance between the center of lens and screen

H: Screen height (different from the aspect ratio of the projected image)

The distance between the lens and the screen varies depending on the attached lens, type of the input signal or size of the projected image. Choose the most suitable distance (L) depending on the screen size (W or D).

The formula for calculating the projection distance from the screen width (W, unit: mm) is as follows:

Type of lens	Projection distance calculation formula when inputting a 4K x 2K signal		Projection distance calculation formula when inputting a 16:9 signal		Projection distance calculation formula when inputting a 4:3 signal	
	L(min)	L(max)	L(min)	L(max)	L(min)	L(max)
LKRL-Z115	$1.48 \times W$	$1.81 \times W$	$1.57 \times W$	$1.93 \times W$	$2.11 \times W$	$2.57 \times W$
LKRL-Z117	$1.72 \times W$	$2.39 \times W$	$1.83 \times W$	$2.55 \times W$	$2.45 \times W$	$3.40 \times W$
LKRL-Z119	$1.81 \times W$	$2.94 \times W$	$1.93 \times W$	$3.14 \times W$	$2.57 \times W$	$4.18 \times W$
LKRL-Z122	$2.23 \times W$	$4.03 \times W$	$2.38 \times W$	$4.30 \times W$	$3.17 \times W$	$5.73 \times W$
LKRL-Z140	$3.81 \times W$	$7.12 \times W$	$4.06 \times W$	$7.59 \times W$	$5.42 \times W$	$10.13 \times W$
LKRL-90	$0.9 \times W$		$0.96 \times W$		$1.28 \times W$	

The formula for calculating the projection distance from the screen diagonal length (D, unit: inch) is as follows:

Type of lens	Projection distance calculation formula when inputting a 4K x 2K signal		Projection distance calculation formula when inputting a 16:9 signal		Projection distance calculation formula when inputting a 4:3 signal	
	L(min)	L(max)	L(min)	L(max)	L(min)	L(max)
LKRL-Z115	$1.31 \times D$	$1.60 \times D$	$1.36 \times D$	$1.67 \times D$	$1.67 \times D$	$2.05 \times D$
LKRL-Z117	$1.55 \times D$	$2.15 \times D$	$1.65 \times D$	$2.30 \times D$	$2.21 \times D$	$3.06 \times D$
LKRL-Z119	$1.63 \times D$	$2.65 \times D$	$1.74 \times D$	$2.83 \times D$	$2.31 \times D$	$3.76 \times D$
LKRL-Z122	$2.01 \times D$	$3.63 \times D$	$2.13 \times D$	$3.86 \times D$	$2.85 \times D$	$5.16 \times D$
LKRL-Z140	$3.43 \times D$	$6.41 \times D$	$3.65 \times D$	$6.83 \times D$	$4.88 \times D$	$9.12 \times D$
LKRL-90	$0.81 \times D$		$0.86 \times D$		$1.15 \times D$	

The projection distance (L) that is decided by the screen width (W) is as shown below.

For the projection distance charts of the optional lenses not mentioned below, refer to the mounting instructions supplied with each lens.

Using the LKRL-Z115 projection lens

When projecting a 4096-pixel (4K × 2K) image at the maximum horizontal picture element

Unit: mm
(inches)

W	4500 (177 1/5)	5000 (196 6/7)	6000 (236 2/9)	7000 (275 3/5)	8000 (315)	9000 (354 1/3)	10000 (393 5/7)	12000 (472 4/9)	14000 (551 1/6)	16000 (630)
L(min)	6554 (258)	7295 (287 2/9)	8778 (345 3/5)	10261 (404)	11743 (462 1/3)	13226 (520 5/7)	14709 (579)	17674 (695 5/6)	20639 (812 4/7)	23605 (929 1/3)
L(max)	8056 (317 1/6)	8964 (353)	10780 (424 2/5)	12596 (496)	14412 (567 2/5)	16228 (638 8/9)	18044 (710 2/5)	21676 (853 2/5)	25308 (996 3/8)	28940 (1139 3/8)
H1 a)	2373 (93 3/7)	2637 (103 4/5)	3164 (124 4/7)	3691 (145 1/3)	4219 (166)	4746 (186 6/7)	5273 (207 5/8)	6328 (249 1/7)	7383 (290 2/3)	8438 (332 1/5)
H2 b)	1883 (74 1/8)	2092 (82 3/8)	2510 (98 5/6)	2929 (115 1/3)	3347 (131 7/9)	3766 (148 1/4)	4184 (164 3/4)	5021 (197 2/3)	5858 (230 5/8)	6695 (263 4/7)

mm:

$$L(\min) = (W - 79.675) / 0.67446$$

$$L(\max) = (W - 63.762) / 0.55067$$

$$H1 = W \times 0.52730$$

$$H2 = W \times 0.41840$$

inch:

$$L(\min) = (W - 3.1368) / 0.67446$$

$$L(\max) = (W - 2.5103) / 0.55067$$

$$H1 = W \times 0.52730$$

$$H2 = W \times 0.41840$$

a) Screen height when projecting a 4096 × 2160-pixel (4K single screen) image on the screen.

b) Screen height when projecting a 4096 × 1714-pixel (aspect ratio 2.39:1) image on the screen.

When projecting a 3840-pixel (aspect ratio 16:9) image at the maximum horizontal picture element

Unit: mm
(inches)

W	4500 (177 1/6)	5000 (196 6/7)	6000 (236 2/9)	7000 (275 3/5)	8000 (315)	9000 (354 1/3)	10000 (393 5/7)	12000 (472 4/9)	14000 (551 1/6)	16000 (630)
L(min)	7001 (275 5/8)	7791 (306 3/4)	9373 (369)	10955 (431 2/7)	12537 (493 4/7)	14118 (555 5/6)	15700 (618 1/9)	18863 (742 2/3)	22027 (867 1/5)	25190 (991 3/4)
L(max)	8600 (338 4/7)	9568 (376 5/7)	11505 (453)	13442 (529 2/9)	15379 (605 1/2)	17316 (681 3/4)	19253 (758)	23127 (910 1/2)	27000 (1063)	30874 (1215 1/2)
H1 a)	2531 (99 2/3)	2813 (110 3/4)	3375 (132 7/8)	3938 (155)	4500 (177 1/6)	5063 (199 1/3)	5625 (221 1/2)	6750 (265 3/4)	7875 (310)	9000 (354 1/3)
H2 b)	2432 (95 3/4)	2703 (106 2/5)	3243 (127 2/3)	3784 (149)	4324 (170 1/4)	4865 (191 1/2)	5405 (212 4/5)	6486 (255 3/8)	7568 (298)	8649 (340 1/2)

mm:

$$L(\min) = (W - 73.944) / 0.63223$$

$$L(\max) = (W - 59.873) / 0.51629$$

$$H1 = W \times 0.56250$$

$$H2 = W \times 0.54050$$

inch:

$$L(\min) = (W - 2.9112) / 0.63223$$

$$L(\max) = (W - 2.3572) / 0.51629$$

$$H1 = W \times 0.56250$$

$$H2 = W \times 0.54050$$

a) Screen height when projecting a 3840 × 2160-pixel (aspect ratio 16:9) image.

b) Screen height when projecting a 3996 × 2160-pixel (aspect ratio 1.85:1) image.

When projecting a 2880-pixel (aspect ratio 4:3) image at the maximum horizontal picture element

Unit: mm
(inches)

W	3500 (137 4/5)	4000 (157 1/2)	4500 (177 1/6)	5000 (196 6/7)	6000 (236 2/9)	7000 (275 3/5)	8000 (315)	9000 (354 1/3)	10000 (393 5/7)	12000 (472 4/9)
L(min)	7271 (286 1/4)	8326 (327 4/5)	9381 (369 1/3)	10436 (410 8/9)	12547 (494)	14657 (577)	16767 (660 1/8)	18878 (743 1/5)	20988 (826 2/7)	25208 (992 4/9)
L(max)	8922 (351 1/4)	10213 (402)	11504 (453)	12795 (503 3/4)	15377 (605 2/5)	17959 (707)	20541 (808 5/7)	23123 (910 1/3)	25705 (1012)	30869 (1215 1/3)

W	3500 (137 ⁴ / ₅)	4000 (157 ¹ / ₂)	4500 (177 ¹ / ₆)	5000 (196 ⁶ / ₇)	6000 (236 ² / ₉)	7000 (275 ³ / ₅)	8000 (315)	9000 (354 ¹ / ₃)	10000 (393 ⁵ / ₇)	12000 (472 ⁴ / ₉)
H ^{a)}	2625 (103 ¹ / ₃)	3000 (118 ¹ / ₉)	3375 (132 ⁷ / ₈)	3750 (147 ² / ₃)	4500 (177 ¹ / ₆)	5250 (206 ² / ₃)	6000 (236 ² / ₉)	6750 (265 ³ / ₄)	7500 (295 ² / ₇)	9000 (354 ¹ / ₃)

mm: L (min) = (W - 54.449) / 0.47387

L (max) = (W - 44.662) / 0.38729

H = W × 0.75000

inch: L (min) = (W - 2.1436) / 0.47387

L (max) = (W - 1.7583) / 0.38729

H = W × 0.75000

a) Screen height when projecting a 2880 × 2160-pixel (aspect ratio 4:3) image.

Using the LKRL-Z140 projection lens

When projecting a 4096-pixel (4K × 2K) image at the maximum horizontal picture element

Unit: mm
(inches)

W	4500 (177 ¹ / ₆)	5000 (196 ⁶ / ₇)	6000 (236 ² / ₉)	7000 (275 ³ / ₅)	8000 (315)	9000 (354 ¹ / ₃)	10000 (393 ⁵ / ₇)
L(min)	16937 (666 ⁴ / ₅)	18792 (739 ⁵ / ₆)	22502 (885 ⁸ / ₉)	26212 (1032)	29922 (1178)	33632 (1324)	37342 (1470 ¹ / ₇)
L(max)	31943 (1257 ³ / ₅)	35466 (1396 ² / ₇)	42512 (1673 ² / ₃)	49558 (1951)	56604 (2228 ¹ / ₂)	63649 (2505 ⁷ / ₈)	70695 (2783 ² / ₇)
H1 ^{a)}	2373 (93 ³ / ₇)	2637 (103 ⁴ / ₅)	3164 (124 ⁴ / ₇)	3691 (145 ¹ / ₃)	4219 (166)	4746 (186 ⁶ / ₇)	5273 (207 ⁵ / ₈)
H2 ^{b)}	1883 (74 ¹ / ₈)	2092 (82 ³ / ₈)	2510 (98 ⁵ / ₆)	2929 (115 ¹ / ₃)	3347 (131 ⁷ / ₉)	3766 (148 ¹ / ₄)	4184 (164 ³ / ₄)

mm:

L (min) = (W + 65.304) / 0.26955

L (max) = (W + 33.615) / 0.14193

H1 = W × 0.52730

H2 = W × 0.41840

inch:

L (min) = (W + 2.5710) / 0.26955

L (max) = (W + 1.3234) / 0.14193

H1 = W × 0.52730

H2 = W × 0.41840

a) Screen height when projecting a 4096 × 2160-pixel (4K single screen) image.

b) Screen height when projecting a 4096 × 1714-pixel (aspect ratio 2.39:1) image.

When projecting a 3840-pixel (aspect ratio 16:9) image at the maximum horizontal picture element

Unit: mm
(inches)

W	4500 (177 ¹ / ₆)	5000 (196 ⁶ / ₇)	6000 (236 ² / ₉)	7000 (275 ³ / ₅)	8000 (315)	9000 (354 ¹ / ₃)	10000 (393 ⁵ / ₇)
L(min)	18062 (711)	20042 (789)	24002 (945)	27961 (1100 ⁵ / ₆)	31921 (1256 ³ / ₄)	35881 (1412 ⁵ / ₈)	39841 (1568 ¹ / ₂)
L(max)	34047 (1340 ³ / ₇)	37803 (1488 ¹ / ₃)	45317 (1784 ¹ / ₈)	52830 (2080)	60343 (2375 ³ / ₄)	67857 (2671 ¹ / ₂)	75370 (2967 ¹ / ₃)
H1 ^{a)}	2531 (99 ² / ₃)	2813 (110 ³ / ₄)	3375 (132 ⁷ / ₈)	3938 (155)	4500 (177 ¹ / ₆)	5063 (199 ¹ / ₃)	5625 (221 ¹ / ₂)
H2 ^{b)}	2432 (95 ³ / ₄)	2703 (106 ² / ₅)	3243 (127 ² / ₃)	3784 (149)	4324 (170 ¹ / ₄)	4865 (191 ¹ / ₂)	5405 (212 ⁴ / ₅)

mm:

L (min) = (W + 61.345) / 0.25254

L (max) = (W + 31.485) / 0.13310

H1 = W × 0.56250

H2 = W × 0.54050

inch:

L (min) = (W + 2.4152) / 0.25254

L (max) = (W + 1.2396) / 0.13310

H1 = W × 0.56250

H2 = W × 0.54050

a) Screen height when projecting a 3840 × 2160-pixel (aspect ratio 16:9) image.

b) Screen height when projecting a 3996 × 2160-pixel (aspect ratio 1.85:1) image.

When projecting a 2880-pixel (aspect ratio 4:3) image at the maximum horizontal picture element

Unit: mm
(inches)

W	3500 (137 ⁴/₅)	4000 (157 ¹/₂)	4500 (177 ¹/₆)	5000 (196 ⁶/₇)	6000 (236 ²/₉)	7000 (275 ³/₅)	8000 (315)
L(min)	18759 (738 ¹ / ₂)	21404 (842 ² / ₃)	24050 (946 ⁵ / ₆)	26695 (1051)	31986 (1259 ¹ / ₃)	37277 (1467 ³ / ₅)	42568 (1676)
L(max)	35266 (1388 ² / ₅)	40270 (1585 ³ / ₇)	45274 (1782 ⁴ / ₉)	50278 (1979 ¹ / ₂)	60287 (2373 ¹ / ₂)	70295 (2767 ¹ / ₂)	80303 (3161 ⁵ / ₉)
H ^{a)}	2625 (103 ¹ / ₃)	3000 (118 ¹ / ₉)	3375 (132 ⁷ / ₈)	3750 (147 ² / ₃)	4500 (177 ¹ / ₆)	5250 (206 ² / ₃)	6000 (236 ² / ₉)

mm: L (min) = (W + 45.494) / 0.18900

L (max) = (W + 23.598) / 0.09992

H = W × 0.75000

inch: L (min) = (W + 1.7911) / 0.18900

L (max) = (W + 0.92905) / 0.09992

H = W × 0.75000

^{a)} Screen height when projecting a 2880 × 2160-pixel (aspect ratio 4:3) image.

Before Installation

Necessary clearance for installation and maintenance

For maintenance service and to prevent internal heat build-up, be sure to provide enough room around the projector when it is installed.

For details, see “Necessary Clearance for Installation and Maintenance” (page 41)

About the Mounting Platform

This projector can be installed at an angle of ± 90 degrees. To install at ± 90 degrees angle, attach a mounting platform that can return to the normal angle as shown in the figure below to this projector.

The mounting platform is not available as an optional accessory. Prepare the mounting platform shown in “Mounting Platform Dimensions” (page 39).

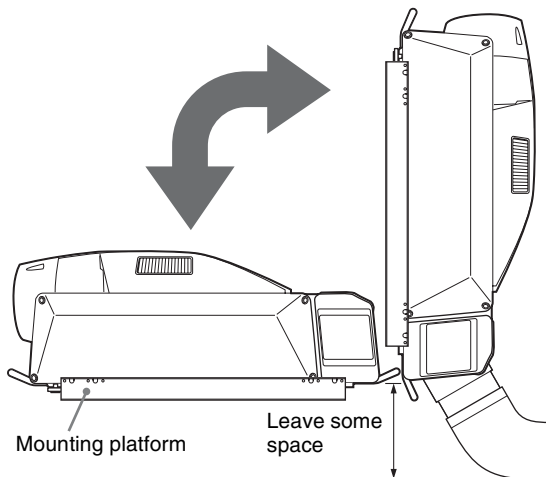

Note

Attach the optional LKRA-001 exhaust duct adaptor when installing at ± 90 degrees angle. When attaching the adaptor, be sure to provide enough room for smooth exhaust flow and take care not to bend the duct.

Positioning the Projector towards the Screen

Install the projector so that the center of the lens is between the bottom edge and the top edge of the screen. You can move the picture position vertically by half of the screen vertical size using the lens shift adjustment.

Vertical positioning (side view)

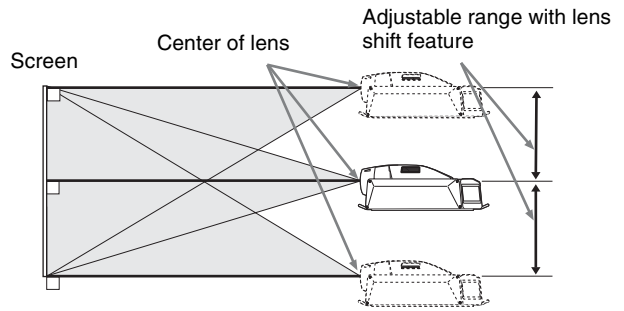

Horizontal positioning (top view)

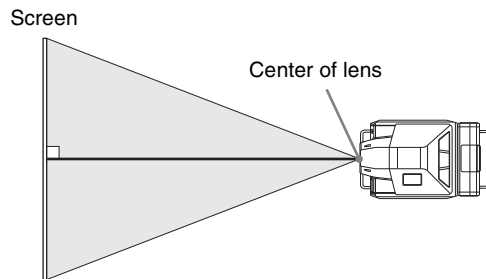

Installing Lamp Houses

The lamps for the light source of the projector are not installed in the factory.

Depending on the model, install the optional lamp houses into the projector.

- LKRX-B110 projection lamp house for SRX-T110
- LKRX-B105 projection lamp house for SRX-T105

For the lamp house installation method, refer to the operating instructions supplied with each lamp house.

Attaching the Lens

Attach one of the optional lenses to the projector according to your purpose.

The procedure below describes how to attach the following lenses to the projector.

- LKRL-Z115 1.48- to 1.81-times zoom lens
- LKRL-Z140 3.81- to 7.12-times zoom lens

For attachment of the optional lenses not mentioned above, refer to the mounting instructions supplied with each lens.

Note

Handle the lens carefully as it is very heavy.

- 1 Loosen the four screws on the lens cover with a hexagonal wrench, then remove the lens cover.

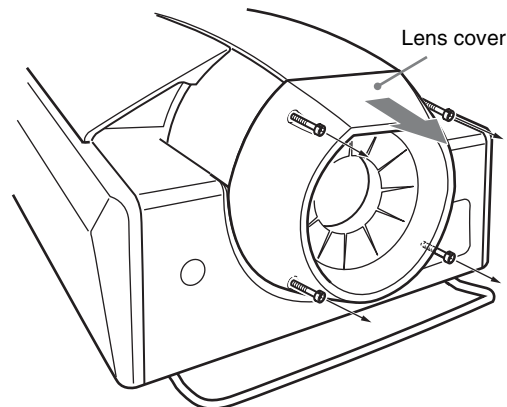

- 2 Holding the lens with both hands, align the holes on the lens with the positioning pins on the projector, then insert the lens straight into the lens attachment part.

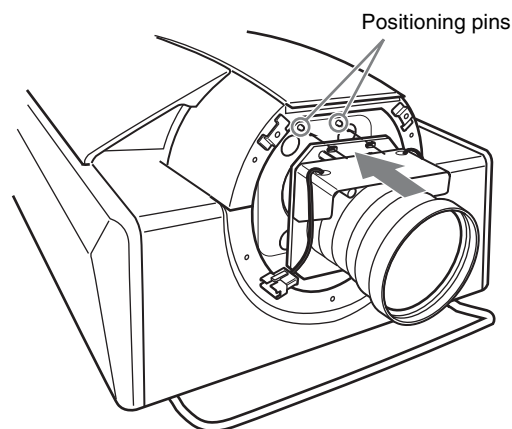

- 3 Tighten the supplied four screws (M8) with a screwdriver to secure the lens.

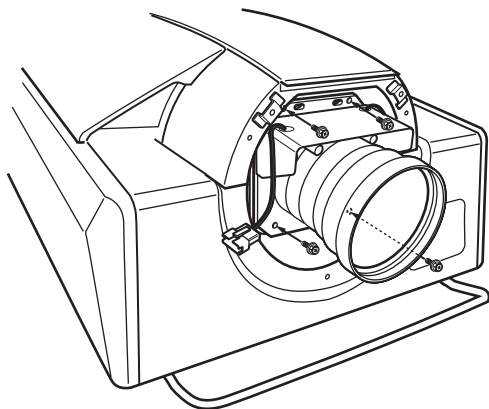

- The lens scratches easily, so when handling it, always place it gently on a stable and level surface in a horizontal position.
- Avoid touching the lens surface.

4 Connect the connectors for power focus and zoom on the lens to those on the projector.

The “FOCUS” and “ZOOM” indications will be found on the connectors of the lens and the projector. Be sure to connect each of them correctly.

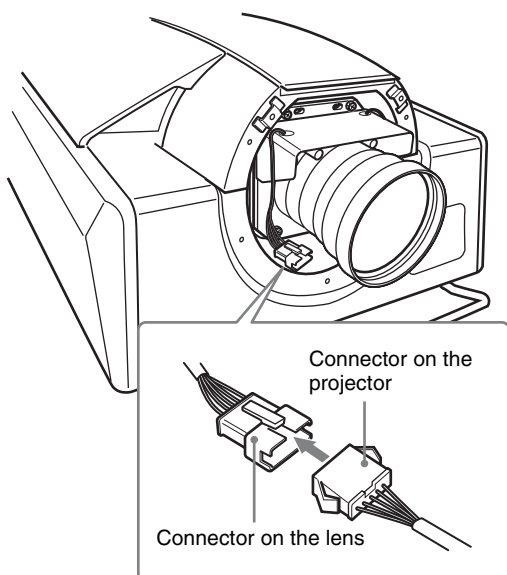

5 Replace the lens cover and tighten it with the four screws. Be sure to put the connectors and their wires completely into the projector cabinet before replacing the lens cover.

Notes

- After replacing the lens with a new one, be sure to readjust the zoom and focus settings stored in each FUNCTION button. Otherwise, error message “DATA LOAD FAILURE LENS POSITION SENSOR” may appear.
- When removing the screws from the lens to remove the lens from the projector, be sure to hold the lens with your hands so that the lens does not drop.
- When attaching the lens, be careful not to tighten the lens too firmly.

Using the Optional Input Board

Prepare the optional input boards mentioned below depending on your system requirements, and attach them to the input board attachment part on the left side of the projector.

- LKRI-001 analog input board
- LKRI-002 HD-SDI (4:2:2) input board
- LKRI-003 HD-SDI/DC-SDI (4:4:4) input board

For information on the input boards not mentioned above, refer to the operating instructions supplied with each input board.

Connectors on the LKRI-001

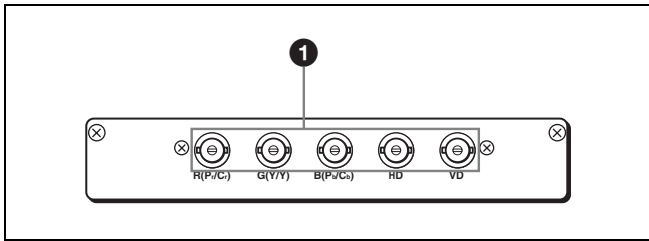

1 R (P_r/C_r)/G (Y/Y)/B (P_b/C_b)/HD/VD input connectors (BNC type)

Inputs the RGB, component or high definition signal from a computer or component equipment.

Connectors on the LKRI-002

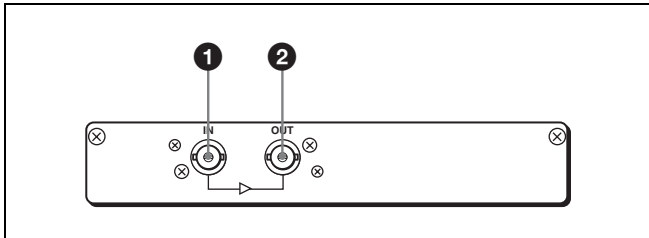

1 IN (HD-SDI input) connector (BNC type)

Connect to the output connector of an HDCAM video recorder/player to input an HDTV serial digital signal.

2 OUT (HD-SDI output) connector (BNC type)

Outputs a digital signal input through the IN connector when the projector is turned on.

Connectors on the LKRI-003

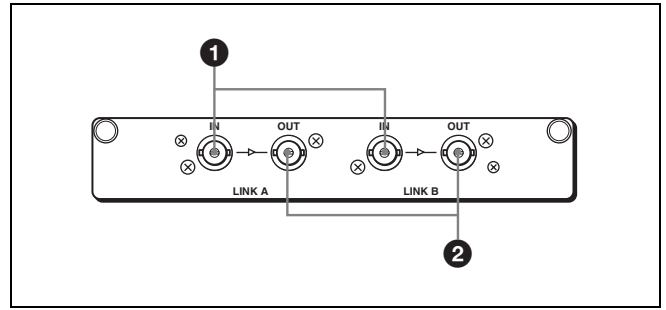

1 LINK A/LINK B IN (HD-SDI input) connectors (BNC-type)

Connect to the output connectors of an HDCAM-SR video recorder/player to input an HD-SDI or DC-SDI signal. Connection of both LINK A and LINK B IN connectors allows Dual-link HD-SDI or Dual-link DC-SDI signal input.

2 LINK A/LINK B OUT (HD-SDI output) connectors (BNC-type)

Output the input signals supplied from the LINK A/LINK B IN connectors by loop-through when the projector is turned on.

Attaching the input board

- 1 Loosen the two screws fully and remove the panel.

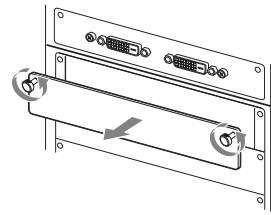

- 2 Push in the input board along the rails.

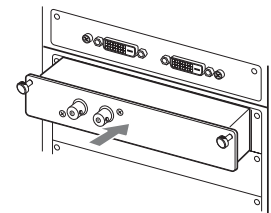

- 3** Tighten the two screws firmly with a torque of 0.8 ± 0.1 N·m.

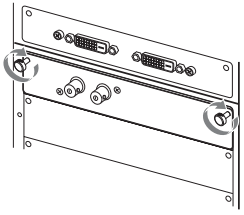

To remove the input board, loosen the screws fully and pull it out.

Attaching the Exhaust Duct Adaptor

Attach the optional exhaust duct adaptor according to the installation situation.

- LKRA-001 8-inch exhaust duct adaptor

For details on attaching the exhaust duct adaptor, refer to the Installation Instructions supplied with LKRA-001.

Connecting the Projector

When you connect the projector, make sure to:

- Turn off all equipment before making any connections.
- Use the proper cables for each connection.
- Insert the cable plugs firmly; loose connections may increase noise and reduce performance of picture signals. When pulling out a cable, be sure to pull it out from the plug, not the cable itself.
- When installing the optional input board, consult your Sony dealer.

Refer also to the instruction manuals of the equipment to be connected.

Connecting a Computer Equipped with a DVI-D Connector

Connect a computer to the DVI-D connector on the optional LKRI-004 DVI interface board or LKRI-005 HDCP DVI board attached to the input board attachment part. A progressive DVI signal can be input.

Setting the DIP switch

Set the following DIP switch(es) at the bottom of LKRI-004 and LKRI-005 boards depending on the input signal type of the connected computer.

- S101 on LKRI-004 board
- S101 and S102 on LKRI-005 board

For details on setting the DIP switches, refer to the *Operating Instructions of LKRI-004 (supplied with LKRI-004)* or the *Operating Instructions of LKRI-005 (supplied with this projector)*.

Connecting with a computer

The illustration below shows an example of connection with INPUT A of the projector.

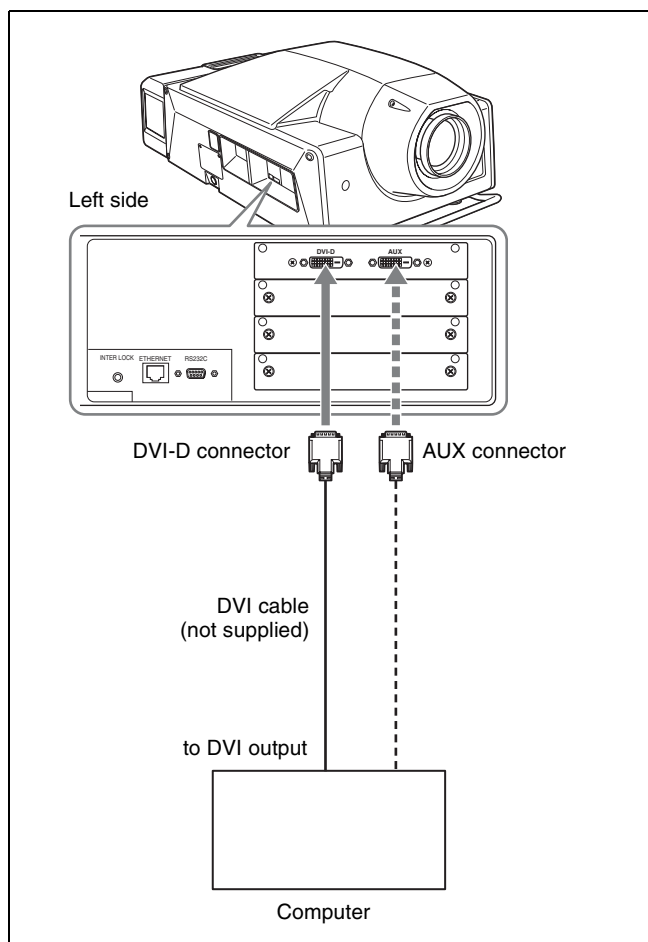

HDCP (High-bandwidth Digital Content Protection) DVI-D signal can also be input when the input signal with specified resolution is input from LKRI-005.

For details, refer to the *Operating Instructions of LKRI-005*.

Notes

- According to the input signal type, set “Signal Mode” on “Input Source” in the PICTURE CONTROL window of the SRX Controller. (page 25)
- When an extension cable is used, the signal may not be input correctly due to signal reduction.
- If you input 10-bit signals from a DVI-D connector only (10-bit single mode), a DVI cable compatible with the Dual-link is required.

Connecting with a Computer Equipped with an Analog RGB Connector

Attach the optional LKRI-001 analog input board to the input board attachment part on the projector, and connect with a computer.

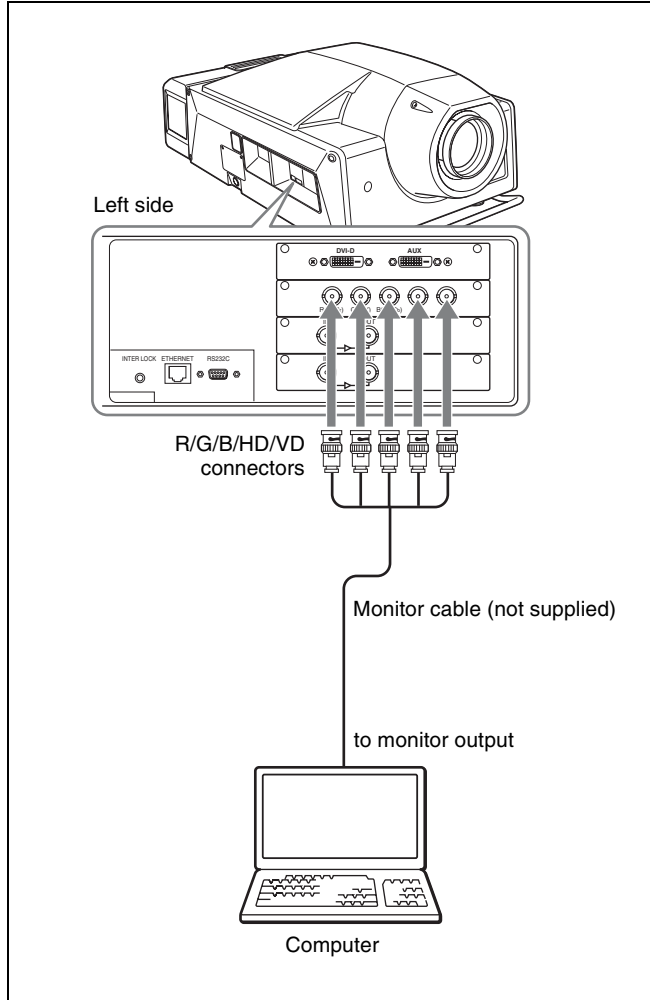

Note

Select “RGB” in “Signal Mode” of “Input Source” in the PICTURE CONTROL window.

For details, see page 25.

Connecting with HD-SDI Equipment

Attach the optional LKRI-002 HD-SDI (4:2:2) or LKRI-003 HD-SDI (4:4:4) input board to the input board attachment part, and connect the HDCAM recorder/player. The illustration below shows an example with the LKRI-002 attached on INPUT B.

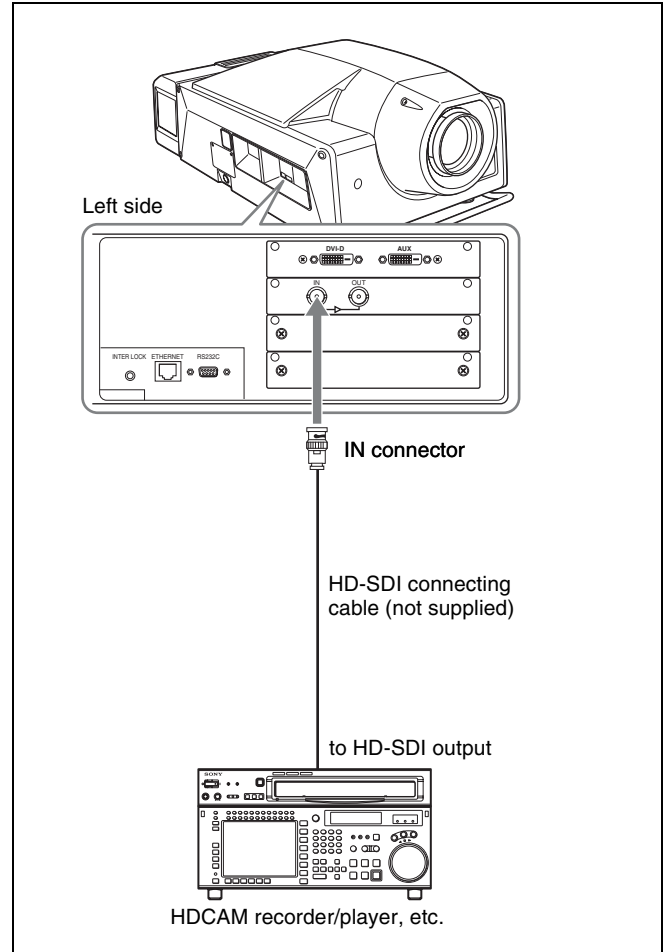

Note

When the LKRI-003 is attached to the projector, select the type of signal with “Signal Mode” of “Input Source” in the PICTURE CONTROL window. For Single-link input, select “YPbPr” or “YPbPr FULL”. For Dual-link input, select “RGB” or “RGB FULL”.

For details, see page 25.

Connecting with Component/Video GBR Equipment

Attach the optional LKRI-001 analog input board to the input board attachment part on the projector, and connect with a DVD recorder/player or analog video equipment equipped with the component output, or an high-definition equipment equipped with a video GBR connector.

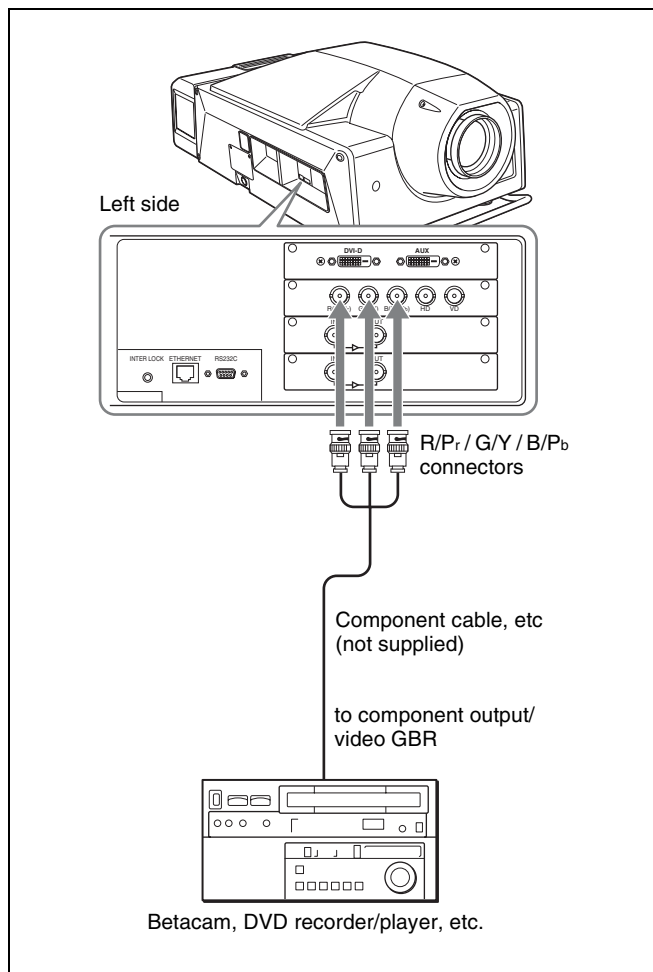

Note

When connecting to the output of HD component equipment, set “Signal Mode” of “Input Source” in the PICTURE CONTROL window to “YPbPr”, and when connecting to the output of HD video GBR equipment, set to “RGB”.

For details, see page 25.

Connecting the AC Power Cord

Use an AC power cord that supports 8AWG, 250 V, 40 A or higher.

Follow the steps below to connect the three-wire power cord to the AC IN terminal on the left side of the projector.

WARNING

- Connection of the main power and the electric wiring work should be done by qualified electricians only.
- Do not plug the power cord into the power supply before completing the following operations.

- 1 Remove the two screws on the terminal cover and remove it.

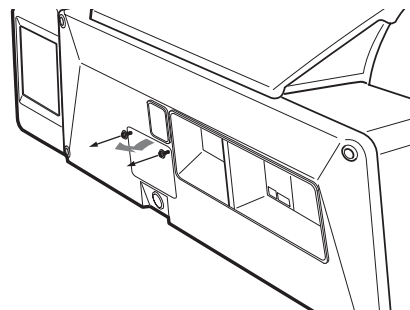

- 2 Remove the two screws on the cable clamp and remove it.

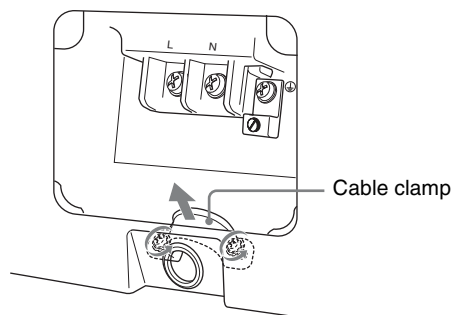

- 3 Pass the AC power cord through the hole beneath the terminal, and tighten the screw for each wire as illustrated.

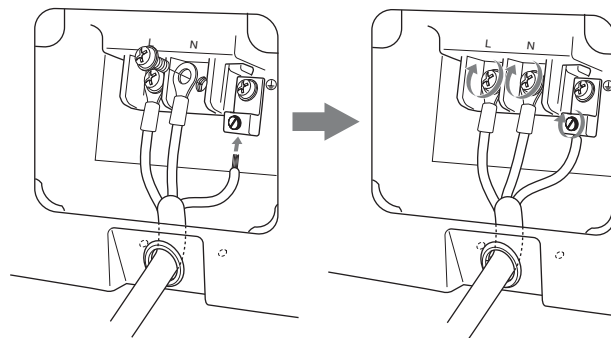

- 4** Fix the AC power cord securely with the cable clamp and the two screws removed in step **2**.
- 5** Replace the terminal cover using the two screws removed in step **1**.

Installing the SRX Controller

Install the supplied SRX Controller on the computer used for controlling.

For the SRX Controller installation method, refer to the Operating Instructions of this projector.

Setting the Projector

Start the SRX Controller. Display the Control Function Menu window, open the SETTING window, and set the functions of the projector.

For details on the Control Function Menu window, see page 24.

Displaying the SETTING Window

- 1 Click the “SETTING” button on the Control Function Menu window.

The authentication dialog appears.

- 2 Enter the password in the “Password” text box, and click the “OK” button.
The default setting of the password is “setting”.

The SETTING window opens.

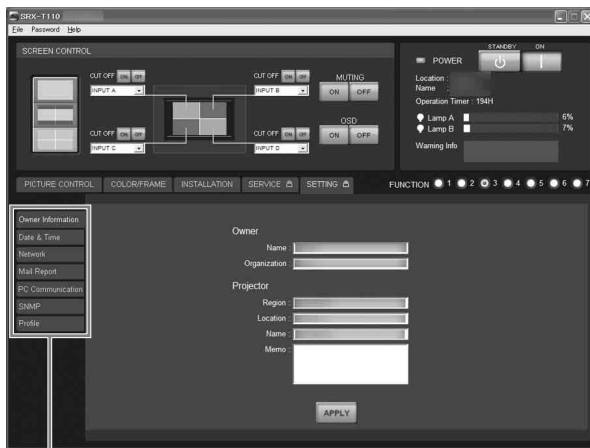

Setting items

- 3 Click the desired setting item on the left of the window.

The selected setting window opens.

When you have completed the settings in each window

Click the “APPLY” button at the lower part of each window. The settings are registered.

Owner Information

The Owner Information window is used to set information on this projector.

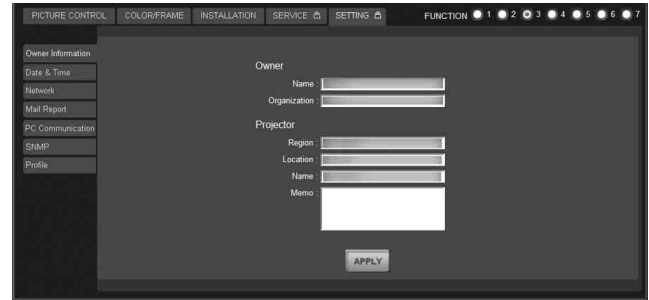

Owner

Name: Enter the name of an owner of the projector.

Organization: Enter the name of an organization.

Projector

Region: Enter the region where the projector is used.

Location: Enter the location where the projector is installed.

Name: Enter the desired name.

Memo: Use to enter notes.

Date & Time

The Date & Time window is used to set the current date and time.

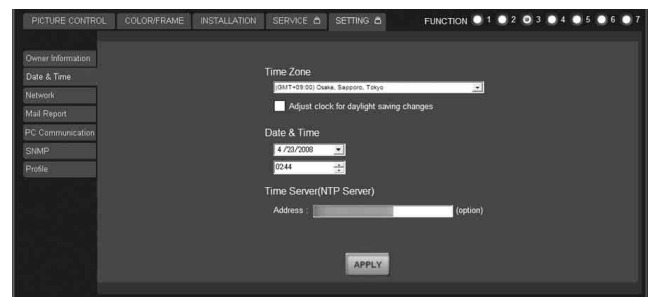



Time Zone

Sets the time difference in the area where the projector is installed. Select the time zone from the drop-down list displayed by clicking .

Adjust clock for daylight saving changes: When you click the check box, the clock is automatically adjusted according to the daylight saving time of the selected time zone.

Date & Time

Clicking  on the date text box displays a calendar. Set the current date using the calendar.

To set the current time, click the hour or minute in the time text box and set it by clicking .

Time Server(NTP Server)

Enter the IP address of the NTP server.

Network

The Network window is used to configure the network setting for the projector.



Internet Protocol (TCP/IP)

Sets the IP address of the projector.

Click either radio button.

Obtain an IP address automatically (DHCP): Click when you obtain an IP address automatically from a DHCP server.

Specify an IP address: Click when you specify a fixed IP address. Sets the following items.

IP Address: Enter the IP address of the projector.

Subnet Mask: Enter the subnet mask.

Default Gateway: Enter the default gateway.

Primary DNS: Enter the IP address of a primary DNS server.

Secondary DNS: Enter the IP address of a secondary DNS server.

LAN

MAC address: Displays the MAC address of the projector.

Speed: Sets the link speed of Ethernet. Select from the drop-down list displayed by clicking .

Mail Report

The Mail Report window is used to set sending e-mail to report the used time of the projection lamps or the operating hours of the projector for maintenance to the preset addresses.



Report Timing

Lamp Timer Reminder: Presets the timing when e-mail is sent for reporting the used time of the lamps.

Maintenance Reminder: Presets the timing when e-mail is sent for reporting the elapsed operating time of the projector for maintenance.

Re-count: Resets the elapsed operating time when you check the check box.

Reporting Sources/Destination

FROM: Enter the e-mail address from which e-mails are sent.

Email Address: Enter the e-mail addresses to which you send e-mails as TO and CC.

Reporting Contents

Error: Check the addresses to which you want to send e-mail for reporting errors.

Lamp Timer/Maintenance: Check the addresses to which you want to send e-mail for reporting "Lamp Timer" and "Maintenance".

Mail Server

Outgoing Mail Server (SMTP): Enter the SMTP (sending mail) server name or the IP address of the SMTP server.

Requires Authentication: If authentication is required when you send e-mails, check the check box and select either way for authentication.

POP before SMTP: Selects when "POP before SMTP" is necessary when e-mail is sent.

POP3 Server: Enter the POP3 server name or the IP address of the POP3 server.

Account Name: Enter the user name to log in to the POP3 server.

Password: Enter the password of the user to log in to the POP3 server.

SMTP Authentication: Selects when “SMTP Authentication” is necessary when e-mail is sent.
Account Name: Enter the user name to log in to the SMTP server.
Password: Enter the password of the user to log in to the SMTP server.

Send Test Mail: Check the check box if you want to send a test mail.

PC Communication

The PC Communication window is used to configure for communication between the projector and the computer for controlling the projector.

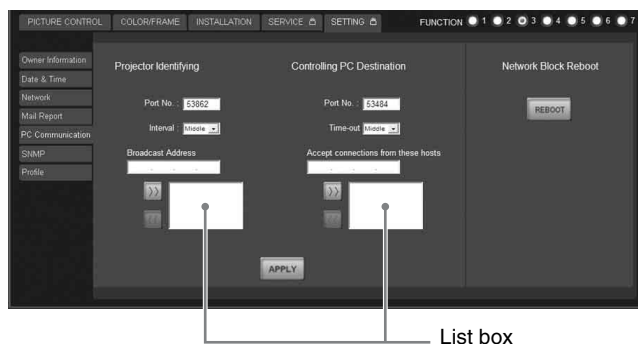

List box

Projector Identifying

Configures the projector.

Port No.: Enter the UDP port number.

Interval: Select the interval at which the IP packets are sent.
 Select from the drop-down list displayed by clicking .

Broadcast Address: Enter the broadcast address.

: Registers the entered IP address in the list.

: Deletes the IP address from the list.

List box: Displays the registered broadcast addresses.

Controlling PC Destination

Configures the computer for controlling the projector.

Port No.: Enter the TCP port number.

Time-out: Select the time when the communication is to end.
 Select from the drop-down list displayed by clicking .

Accept connections from these hosts: Enter the IP address of a host who is allowed to access the projector.

: Registers the entered IP address in the list.

: Deletes the registered IP address from the list.

List box: Displays the registered IP addresses of the hosts allowed to access the projector.

Network Block Reboot

Restarts the Network CPU after the PC Communication settings complete. Click the “REBOOT” button to restart.

SNMP

The window is used to set up SNMP (Simple Network Management Protocol).



List box

SNMP

sysName: Enter the characters for the standard MIB sysName.

Contact: Enter the characters for the standard MIB sysContact.

Location: Enter the characters for the standard MIB sysDescr.

Send authentication trap: Selects when you permit sending authentication trap.

Accept SNMP packets from any host: Selects when you permit access to the projector from any host.

Accept SNMP packets from these hosts: Selects when access to the projector is allowed for specified hosts only. Enter the IP address of the host permitted to access the projector in the text box.

: Register the entered IP address in the list.

: Deletes the registered IP address from the list.

List box: Displays the registered IP addresses of the hosts allowed to access.

Community: Selects and edit the community name.

“Add” button: Click to add the selected community name.

“Edit” button: Click to enter edit mode for attributes of the selected community.

“Remove” button: Click to remove the selected community.

Community Name: Clicking the “Edit” button displays the community name whose attributes can be edited, and the following items are activated:

Rights: Selects the access right.

“Set to List” button: Click to apply the change of attributes.

“Cancel” button: Click to cancel the change of attributes.

Trap Destinations: Enter the IP address of a host for trap destination.

: Register the entered IP address in the list.

: Deletes the registered IP address from the list.

List box: Displays the registered IP addresses of the hosts for trap destination.

Profile

The Profile window is used to save the projector settings in the computer for controlling the projector, or to load the settings saved on the computer for controlling the projector onto the projector.

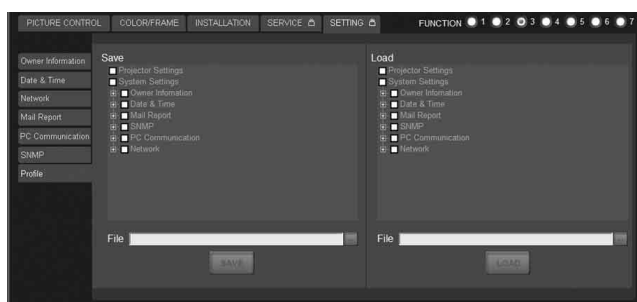

Save

Check the menu items (projector settings) which you want to save to the computer for controlling the projector.

File: Select and edit the filename to be saved. Click  to specify the file to be saved.

“SAVE” button: Click to save the projector settings to the specified file. Only the values of checked items will be saved.

Load

Check the menu items (projector settings) which you want to load to the projector from the computer for controlling the projector.

The settings for some functions cannot be loaded to the projector when the computer for controlling the projector is connected to the projector via network. The menu items for these functions cannot be checked.

File: Select and edit the filename saved on the computer. Click  to specify the saved file.

“LOAD” button: Click to load the settings saved in the specified file to the projector. Only the values of checked items will be loaded.

Adjustments and Settings Using the SRX Controller

Chapter

3

Displaying the Control Function Menu Window

When you install the supplied SRX Controller in a computer, you can operate the picture adjustments, input signal settings, installation settings, etc. from the computer.

Some of the picture adjustments are available using the supplied Remote Commander.

- 1 Double-click the  icon of the SRX Controller in the desktop window of the computer.

The Program Launcher screen appears.

- 2 Select the projector you want to operate by double-clicking the projector.

The T100 Controller starts and the Control Function Menu window appears.



- 3 Click any of the “PICTURE CONTROL”, “COLOR/FRAME” and “INSTALLATION” buttons to display the desired control window.

For details on each setting window, see the relevant window pages.

To clear the Control Function Menu window

Select “Quit” from the “File” menu on the menu bar, or click the  (close) button.

To reset the settings that have been adjusted

Clicking the “RESET” button in the PICTURE CONTROL window resets all the settings of the items for “Signal Adjust” to their factory preset values. To reset the settings of the items for “Frame Adjust” in the COLOR/FRAME window, click the “RESET” button in the COLOR/FRAME window.

To register the settings that have been adjusted

You can register the settings that have been adjusted in the control windows to FUNCTION 1 to 7. As the default setting, the settings are registered to FUNCTION 1. To register the settings to FUNCTION 2 to 7, click one of the FUNCTION 2 to 7 radio buttons, then adjust the items in each window.

You can recall it later to project the picture with the desired setting by clicking one of the FUNCTION radio buttons.

You can also recall the settings registered to the FUNCTION 1, 2 or 3 button with the FUNCTION 1, 2 or 3 button on the Remote Commander.

Note

When you click the FUNCTION button to switch to another FUNCTION setting, the picture will be cut off for up to about 10 seconds. The picture with the selected FUNCTION setting will then appear on the screen.

For details on the items that can be registered, refer to the Operating Instructions of this projector.

About the items that cannot be adjusted

Items that cannot be adjusted depending on the input signal are not displayed in the window.

For details, see “Input Signals And Adjustable/Setting Items” on page 34.

Log function

Clicking the “Save Log” in the “File” menu on the menu bar in the Control Function Menu window saves the communication log between the T100 Controller and this projector up to the moment “Save Log” is clicked. Up to 5 MB can be saved.

PICTURE CONTROL Window

The PICTURE CONTROL window is used to select the input source or to adjust the picture quality. When the screen mode is set to dual-screen mode or quad-screen mode, the items can be independently adjusted for each input channel displayed on the screen.

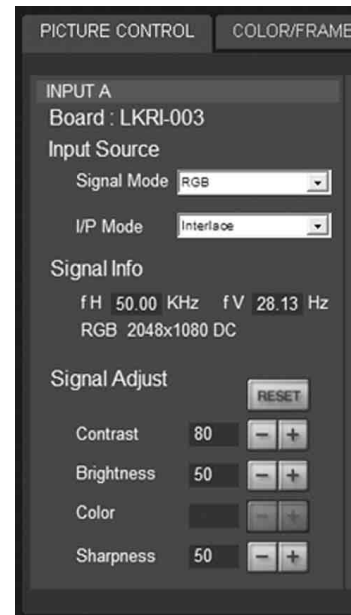

Board

Shows the input board installed in the relative input board slot of the projector.

Input Source

Signal Mode: Click  to open the drop-down list to select the type of signal input from equipment connected to the optional input board.

When the LKRI-004 or LKRI-005 is installed

Select the input signal type of progressive DVI-D signals.

When used in normal, select “8bit Single Full”, which is compatible with DVI1.0 standard and the signal level is Full Range compliance.

When the DTV signal is input, select “8bit Single Limited”, which is compatible with DVI1.0 standard and the signal level is Limited Range compliance.

When the 10-bit signal based on Sony’s unique specification is input, select “10bit Twin Full” or “10bit Single Full” for a signal of Full Range

compliance, or “10bit Twin Limited” or “10bit Single Limited” for a signal of Limited Range compliance.

When the LKRI-001 is installed

Select “YPbPr” to input a high-definition signal from component equipment, and “RGB” to input a high-definition signal from video GBR equipment.

When the LKRI-003 is installed

For Single-link input, select “YPbPr” or “YPbPr FULL”.

For Dual-link input, select “RGB” or “RGB FULL”.

When “RGB” or “YPbPr” is selected, in the case that a 10-bit HD-SDI signal is input and “Contrast” is set to 90 in “Signal Adjust” of the PICTURE CONTROL window, mapping is done so that HD-SDI signal data values ¹⁾ of 64 to 960 are converted to the video levels of 0 to 100% to display an image on the projector.

When “RGB FULL” or “YPbPr FULL” is selected, in the case that a 10-bit HD-SDI signal is input and “Contrast” is set to 90 in “Signal Adjust” of the PICTURE CONTROL window, mapping is done so that HD-SDI signal data values of 0 to 1023 are converted to the video levels of 0 to 100% to display an image on the projector. In this case, inhibition codes included in a 10-bit HD-SDI signal (data area 0 to 3, and 1020 to 1023) are blocked out.

¹⁾ Data value 64 of a 10-bit HD-SDI signal input is equivalent to the video level of 0% (black), and data value 960 equivalent to 100% (white).

I/P Mode: Selects the I/P conversion mode. Depending on the input signal source, set the mode to “Interlace” or “PsF”.

Notes

- This item is available with the interlace or PsF signal input.
- When the LKRI-004 or LKRI-005 is installed, this item is not available.

Clicking the “RESET” button resets the following four settings to the factory preset values.

Contrast: Adjusts the picture contrast. The higher the setting, the greater the contrast.

Brightness: Adjusts the picture brightness. The higher the setting, the brighter the picture.

Color: Adjusts the color intensity. The higher the setting, the greater the intensity.

Sharpness: Adjusts the picture sharpness. The higher the setting, the sharper the picture. The lower the setting, the softer the picture.

Signal Info (Information)



Shows the horizontal and vertical frequencies of the input signal automatically. The values are approximate. The type of the input signal is also displayed.

fH: Displays the horizontal frequency.

fV: Displays the vertical frequency.

Signal Adjust

Adjusts the picture quality of the input signal.

Clicking  increases the setting value, and  decreases it.

COLOR/FRAME Window

The COLOR/FRAME window is used to adjust the input signal.

When the screen mode is set to dual-screen mode or quad-screen mode, the items can be independently adjusted for each input channel displayed on the screen.

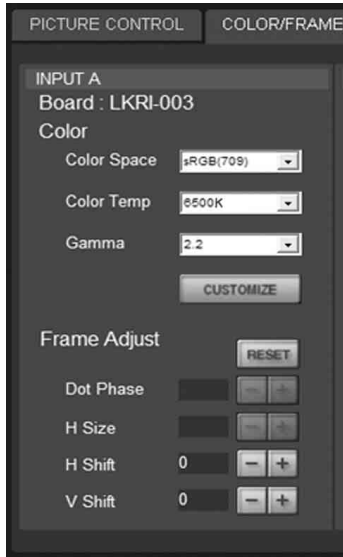

Board

Shows the input board installed in the relative input board slot of the projector.

Color

Adjusts the items so that you can obtain precise color reproduction.

If the color of an image is not correct, check the setting of “Color Space” first.

Select the setting from the drop-down list displayed by clicking .

Color Space: Selects the color gamut.

sRGB(709): Select when projecting a normal high-definition signal or RGB signal.

DCDM: Select when projecting a signal source using the Minimum D-Cinema Color Gamut defined by the DCI Specifications Book/Version 1.0.

CIE XYZ: Select when projecting an XYZ signal from LKRI-003.

Note

Set “Signal Mode” of “Input Source” in the PICTURE CONTROL window to “RGB FULL”.

Adobe RGB: Select when projecting Adobe RGB compatible computer signals.

CUSTOM: Select when projecting a signal using the color gamut defined by the user. The default value is the same as DCDM.

Color Temp (temperature): Selects the color temperature from among “DCI W/P”, “6500K”, “9300K”, “CUSTOM1”, “CUSTOM2” and “CUSTOM3”. 6500K is preset in CUSTOM1 to 3 settings in the factory. “6500K” is recommended for a normal high-definition signal or RGB signal. Set this item to “DCI W/P” to project a movie source.

Gamma: Selects a gamma correction curve. The smaller the value, the brighter the image. Select the setting depending on the signal source. “2.2” is recommended to project a normal high-definition signal or RGB signal.

The gamma value that can be selected will differ according to the optional input board.

When the LKRI-001 or LKRI-002 is installed

Select from “2.6”, “2.2” or “1.8”.

When the LKRI-003, LKRI-004 or LKRI-005 is installed

Select “2.6” or “2.2”, or set a value from 1.80 to 2.59 (except 2.20) in 0.01 steps according to the signal input. This allows projection of an image with optimum brightness.

To set the gamma value in 0.01 steps, set “Gamma” to “1.8”, and click the “CUSTOMIZE” button. Input the values in the Input Gamma Data screen and press the “OK” button.



When a signal is input from the connector on the LKRI-004 or LKRI-005

When you set each item in “Color”, the setting will be written to the color space description area of the EDID ROM.

The values to be written to the EDID ROM are shown below.

Color Space settings

sRGB(709): Red (0.6400, 0.3300), Green (0.3000, 0.6000), Blue (0.1500, 0.0600)

Adobe RGB: Red (0.6400, 0.3300), Green (0.2100, 0.7100), Blue (0.1500, 0.0600)

DCDM, CIE XYZ, CUSTOM: Red (0.6800, 0.3200), Green (0.2650, 0.6900), Blue (0.1500, 0.0600)

Color Temp settings

6500K: White (0.3127, 0.3290)
9300K: White (0.2840, 0.2970)
DCI W/P: White (0.3140, 0.3510)
CUSTOM1 to CUSTOM3: White (0.3127, 0.3290)
 (default values)

Gamma settings

2.6: 2.6

2.2: 2.2

CUSTOM: Value set using CUSTOM

Frame Adjust

Adjusts the horizontal size and the position of the picture. Clicking **+** increases the setting value, and **-** decreases it.

Clicking the “RESET” button resets all the settings of “Frame Adjust” to the factory-preset values.

Dot Phase: Adjusts the phase of the SXRD panels and the input signal. Adjust the value to obtain the clearest picture.

H Size: Adjusts the horizontal size of the picture according to the input signal. As the setting value increases, the horizontal size of the picture becomes larger.

H Shift: Adjusts the horizontal position of the picture. As the setting value increases, the picture moves to the right. As the value decreases, the picture moves to the left.

V Shift: Adjusts the vertical position of the picture. As the setting value increases, the picture moves up. As the value decreases, the picture moves down.

Notes

- Adjustment of “Dot Phase” and “H Size” is available only for analog RGB signals input from a computer.
- If the position of the picture is not adjusted correctly, noise may appear in the blank portion of the screen. This is not a malfunction of the projector. Adjust the picture position correctly with “Frame Adjust”.

INSTALLATION Window

The INSTALLATION window is used to adjust the projected picture and to change the lamp output, etc.

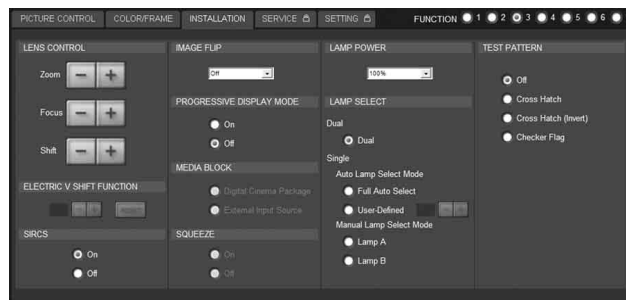

LENS CONTROL

Adjusts the projected picture on the screen.

Zoom +/-: Adjusts the size of the picture. Clicking **+** enlarges the picture size, and **-** reduces the picture size.

Focus +/-: Adjusts the picture focus. Clicking **+** focuses on a picture further back. Clicking **-** focuses on a forward picture.

Shift +/-: Adjusts the vertical position of the picture. Clicking **+** moves the picture upward. Clicking **-** moves it downward.

ELECTRIC V SHIFT FUNCTION

Adjusts the vertical position of the projected pictures electrically. As the setting value increases, the picture moves upward. As the setting value decreases, the picture moves downward.

Clicking the “RESET” button resets the setting to the factory-preset values.

Notes

- This function is effective in the following cases:
 - When single-screen mode is selected
 - When quad-screen mode is selected and “PROGRESSIVE DISPLAY MODE” is set to “On”
- When this function is used for quad-screen mode, all the projected signals should be genlocked to synchronize with each other with a phase difference of less than 5 μ sec. If they are not synchronized, the picture is not displayed correctly.

SIRCS

Sets to enable or disable operations using the remote commander.

To enable operations, press the “On” radio button. To disable operations, press the “Off” radio button.

IMAGE FLIP

Flips the picture.

Select it from the drop-down list displayed by clicking  according to the installed condition of the projector.

Off: Normal projection

H: Flips the picture horizontally

V: Flips the picture vertically

HV: Flips the picture horizontally and vertically

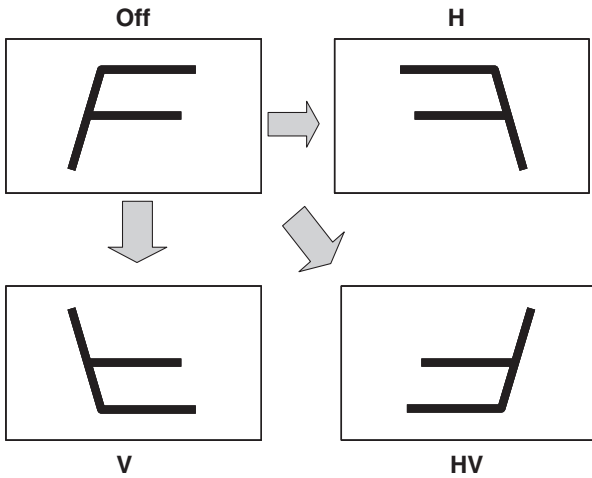

PROGRESSIVE DISPLAY MODE

Normally, click the “Off” radio button.

Click the “On” radio button when the signals from four input boards are used to project a 2048 (1920) × 1080 pixels signal as a 4096 (3840) × 2160 pixels 4K image or to project a 1400 × 1050 pixels (SXGA+) signal as a 2800 × 2100 pixels image in single-screen mode.

SQUEEZE

This function allows the input signal to be displayed on the screen in a converted aspect ratio.

When you click the “On” radio button, the following input signals can be displayed on the screen by horizontal stretching.

- Video 50 Hz or Video 59.94 Hz signal with a 4:3 aspect ratio: Stretched to a 16:9 aspect ratio.

- 720p, 1920 × 1080 or 2048 × 1080 signal with a 16:9 aspect ratio: Stretched to a 2.39:1 aspect ratio. When you click the “Off” radio button, the input signal is displayed without converting the aspect ratio.

Note

This function is available only for projection in single-screen mode.

LAMP POWER

Adjusts the lamp power output.

Select it from the drop-down list displayed by clicking .

You can reduce the lamp power to 93%, 86%, 79%, 72%, 65%, 58% or 51%. Selecting “100%” allows you to obtain the brightest projection image.

Note

Switching the lamp output frequently may reduce the lamp life. Use of the defined lamp output is recommended.

LAMP SELECT



Selects whether to use one of two lamps or both lamps.

Dual: Select when using two lamps.

Single: Select when using only one of two lamps.

In Single, you can further select the lamp to be used automatically or manually.

Auto Lamp Select Mode

When you click the “Full Auto Select” radio button, the lamp with fewer used hours is automatically turned on. When you use the projector for a long period of time, click the “User-Defined” radio button. If you specify the hour between 4 and 24 hours by clicking the  /  buttons, the two lamps turn on alternately at the interval of the specified hours.

Manual Lamp Select Mode

You can specify the lamp to be used by clicking the “Lamp A” or “Lamp B” radio button.

Note

If you switch “LAMP SELECT” from “Single” to “Dual” or when either Lamp A or Lamp B switches to turn on, the projected image will be cut off momentarily (up to 10 seconds).

TEST PATTERN

Displays a built-in test pattern on the screen for adjusting the picture with no signal input from external equipment. Click the radio button of the desired test pattern from among “Cross Hatch”, “Cross Hatch (Invert)” and “Checker Flag”. When you do not display a built-in test pattern, click the “Off” radio button.

Note

While a built-in test pattern is displayed on the screen, you cannot change the screen mode and input select mode, and cannot adjust the PICTURE CONTROL and COLOR/FRAME.

SERVICE Window

The SERVICE window is used for adjustment by your Sony dealer.

Displaying the SERVICE Window

When you click the “SERVICE” button in the Control Function Menu window, the authentication dialog opens. Enter the password in the “Password” text box, then click “OK”.

The default setting of the password is “service”.

The SERVICE window is displayed.

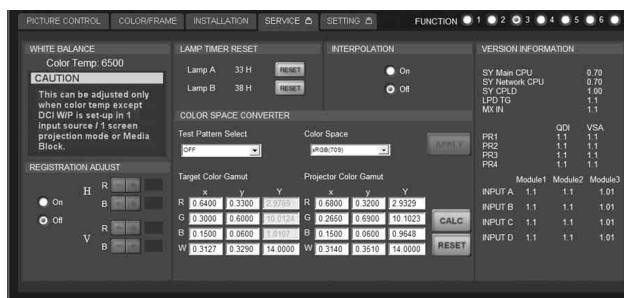

WHITE BALANCE

Adjusts each of Gain R (red)/G (green)/B (blue) and Bias R (red)/G (green)/B (blue) to obtain the desired color temperature.

Use to adjust the slight color difference between the projectors when multiple projectors are used together. It is recommended to perform “Correcting the Color Characteristics (Color Space Converter)” (page 32) for adjusting the white balance when a single projector is used.

Notes

- The white balance can be adjusted only when the screen mode is set to single-screen mode.
- The adjusted values will only be reflected in “Color Temp” of the currently selected input signals.

Adjustment when multiple projectors are used together

Adjust all the projectors using the “COLOR SPACE CONVERTER” (page 32) and output an 80% white signal. Choose a projector to be used as the color base and change the Gain value of the other projectors to match the color with the color base projector.

Bias adjustment is not required at this time.

REGISTRATION ADJUST

A red and blue picture element can be moved for registration up to two picture elements vertically and horizontally.

Click the “On” radio button to enable you to move a red and blue picture element. When you click the “Off” radio button, you cannot move a picture element.

H: Moves the picture elements horizontally.

When you click the R or button, you can move a red picture element right or left up to two elements each.

When you click the B or button, you can move a blue picture element right or left up to two elements each.

V: Moves the picture elements vertically.

When you click the R or button, you can move a red picture element up or down up to two elements each.

When you click the B or button, you can move a blue picture element up or down up to two elements each.

Notes

The following symptoms appear on the displayed picture after you have moved the picture elements:

- In single-screen mode with four signal sources input, two picture elements each on the upper, lower, left and right sides may be invisible as the visible aspect ratio is 4092 × 2156 dots.
- In dual-screen mode with two signal sources input, two picture elements each on the left and right sides are not visible, and a black vertical line may appear in the center of the screen.
- In quad-screen mode with four signal sources input, two picture elements each on the upper, lower, left and right sides are not visible, and black vertical and horizontal lines may appear in the center of the screen.

LAMP TIMER RESET

The used hours of Lamp A and Lamp B are displayed. Clicking the “RESET” button resets the time to “0 H”. Reset the time after replacing the lamp with a new one.

INTERPOLATION

When projecting a 2K-resolution image, set to “On”. You can obtain high-resolution picture quality with a smooth image.

When set to “Off”, the projected image appears rough.

COLOR SPACE CONVERTER

The color characteristics of the projector can be corrected for each color gamut, “sRGB(709)”, “DCDM” or “Adobe RGB”.

For details on the procedures, see “Correcting the Color Characteristics (Color Space Converter)” on page 32.

VERSION INFORMATION

Displays the version information on this projector.

Correcting the Color Characteristics (Color Space Converter)

The color characteristics of the projector can be corrected after measuring with a chroma meter.

The signals used during color space correction of “sRGB(709)” or “Adobe RGB” are different from the signals used during color space correction of “DCDM”.

To adjust the color space “sRGB(709)” or “Adobe RGB”

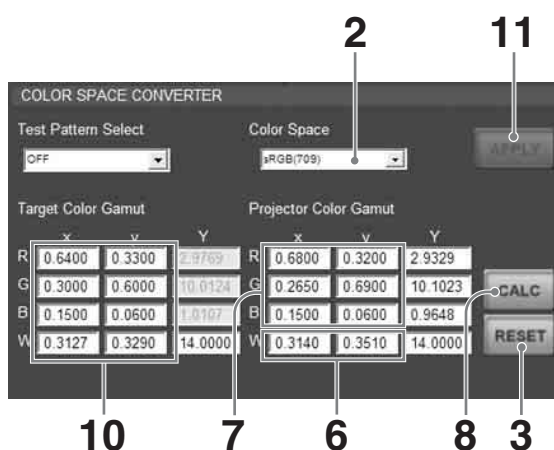

- 1 Open the SERVICE window. (See page 30.)
- 2 Select “sRGB(709)” or “Adobe RGB” in “Color Space” under “COLOR SPACE CONVERTER”.
- 3 Click the “RESET” button.
- 4 Connect to the user’s computer and output an 80% white signal.
A 80% white image will be displayed.
- 5 Measure the values of x and y in the center of the screen by the chroma meter.
- 6 Enter the measured x and y values in the text boxes for “W” under “Projector Color Gamut.”
- 7 Similarly, output 80% red, 80% green and 80% blue signals from the user’s computer, measure the values of x and y in the center of the screen and enter the measured x and y values in the respective text boxes.
- 8 Click the “CALC” button.

- 9 Output 80% red, 80% green and 80% blue signals again and measure the values of x and y in the center of the screen.
- 10 Check that the difference between the measured value and the value for “Target Color Gamut” is within the range as shown below.

80% green signal when Adobe RGB is selected: within ± 0.01

Other than the above: within ± 0.005

- 11 Click the “APPLY” button if the difference is within the range.

If the difference is out of the range, repeat steps 4 to 10 until the value is within the range.

To adjust the color space “DCDM”

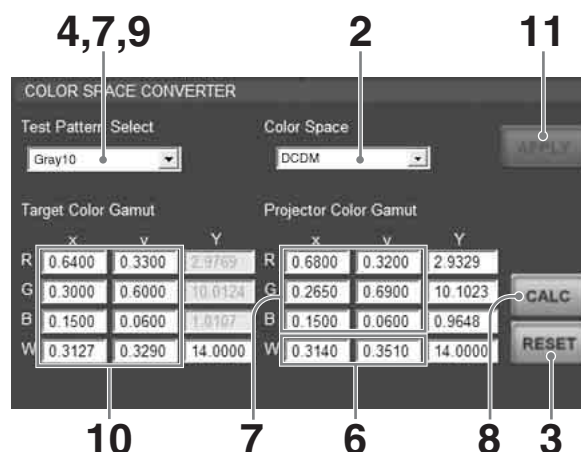

- 1 Open the SERVICE window. (See page 30.)
- 2 Select “DCDM” in “Color Space” under “COLOR SPACE CONVERTER”.
- 3 Click the “RESET” button.
- 4 Select “Gray10” in “Test Pattern Select” under “COLOR SPACE CONVERTER”.
The test pattern for Gray10 will be displayed.
- 5 Measure the values of x and y in the center of the screen by the chroma meter.
- 6 Enter the measured x and y values in the text boxes for “W” under “Projector Color Gamut.”
- 7 Similarly, select “Red1”, “Green1” and “Blue1” from “Test Pattern Select”, measure the values of x and y in the center of the screen and enter the measured x and y values in the respective text boxes.

- 8** Click the “CALC” button.
- 9** Select “Gray10”, “Red1”, “Green1” and “Blue1” in “Test Pattern Select” again and measure the values for x and y in the center of the screen.
- 10** Check that the difference between the measured value and the value for “Target Color Gamut” is within ± 0.005 .
- 11** Click the “APPLY” button if the difference is within ± 0.005 .

If the difference is greater than ± 0.005 , repeat steps **4** to **10** until the value is within ± 0.005 .



Input Signals And Adjustable/Setting Items

Some items of “Signal Adjust” in the PICTURE CONTROL window and “Frame Adjust” in the COLOR/FRAME window are not adjusted or set depending on the input signals. Items that cannot be adjusted depending on the input signal are not displayed in the window.

Signal Adjust

Item	Input signal					
	Component	Video GBR	Computer	HD-SDI	DVI-D	4K
Contrast	●	●	●	●	●	●
Brightness	●	●	●	●	●	●
Color	●	–	–	●	–	–
Sharpness	●	●	●	●	–	–

- : Adjustable/can be set
- : Not adjustable/cannot be set

Frame Adjust

Item	Input signal					
	Component	Video GBR	Computer	HD-SDI	DVI-D	4K
Dot Phase	–	–	●	–	–	–
H Size	–	–	●	–	–	–
H Shift	●	●	●	●	●	–
V Shift	●	●	●	●	●	–

- : Adjustable/can be set
- : Not adjustable/cannot be set

Lamp Life

Recommended time for replacement of the projection lamp is as follows:

SRX-T110: Approx. 800 hours

SRX-T105: Approx. 1,000 hours

The “Lamp A” and “Lamp B” bar indicators in the Control Function Menu window become red when the time for replacement is coming near. The percentage indicates the time used before the recommended time for replacement. Use them as a guide.

Be sure to ask your Sony dealer to replace the projection lamp and lamp house.

Note

Replacement of the lamp by unqualified service personnel may result in explosion or fire.

Continuously lighting the lamp will reduce its lamp life. Be sure to off the lamp for one to two hours after continuously lighting for 24 hours.

To replace the lamp

When replacing the lamp, use the optional projection lamp for replacement.

LKRX-110 projection lamp for SRX-T110

LKRX-105 projection lamp for SRX-T105

Use of any lamps other than the above may cause damage of the projector.

Contact your Sony dealer for replacement of the lamp.

Caution

The lamp and lamp house remain at a high temperature after the projector is turned off. If you touch the lamp, you may burn your finger. When you replace the lamp, wait for at least an hour for the lamp to cool.

Error Messages

The error messages are displayed in the STATUS MESSAGE window on the left side of projector and the Error display window of the SRX Controller. If there are two or more messages, a displayed message changes each five seconds.

No.	Error messages	Meaning	Remedy
1	INPUT-A POWER ALERT	Trouble with power of INPUT A board	Replace the INPUT A board.
2	INPUT-B POWER ALERT	Trouble with power of INPUT B board	Replace the INPUT B board.
3	INPUT-C POWER ALERT	Trouble with power of INPUT C board	Replace the INPUT C board.
4	INPUT-D POWER ALERT	Trouble with power of INPUT D board	Replace the INPUT D board.
5	PR-284_1 POWER ALERT	Trouble with power of PR-284 board at the top	Replace the corresponding PR-284 board.
6	PR-284_2 POWER ALERT	Trouble with power of PR-284 board on the second row	Replace the corresponding PR-284 board.
7	PR-284_3 POWER ALERT	Trouble with power of PR-284 board on the third row	Replace the corresponding PR-284 board.
8	PR-284_4 POWER ALERT	Trouble with power of PR-284 board on the fourth row	Replace the corresponding PR-284 board.
9	24V POWER SUPPLY ALERT	The projector has failed to supply 24V power.	Overload on the 24 V line. Replace the AC inlet on the projector.
10	16V POWER SUPPLY ALERT	The projector has failed to supply 16V power.	Overload on the 16 V line. Replace the AC inlet on the projector.
11	PR-284_1 DETACHED	The PR-284 board is not attached correctly on the top row.	Attach the PR-284 board on the top row correctly.
12	SXRD PANEL TEMPERATURE ALERT	The temperature of the panels is too high.	Check the panel cooling fan or the ventilation holes for intake.
13	LAMP_A FAN ALERT	Trouble with the sirocco fan for Lamp A, or the harness is disconnected or down.	Check the connection of the Lamp A fan, or replace the fan.
14	LAMP_B FAN ALERT	Trouble with the sirocco fan for Lamp B, or the harness is disconnected or down.	Check the connection of the Lamp B fan, or replace the fan.
15	LAMP_A POWER SUPPLY UNIT FAN ALERT	Trouble with the fan for Lamp A power (ballast), or the harness is disconnected or down.	Check the connection between the Lamp A power and the SY board, or replace the fan for Lamp A power.
16	LAMP_B POWER SUPPLY UNIT FAN ALERT	Trouble with the fan for Lamp B power (ballast), or the harness is disconnected or down.	Check the connection between the Lamp B power and the SY board, or replace the fan for Lamp B power.
17	PR-284 FAN FAILURE	Trouble with the fan for PR-284 board, or the harness is disconnected or down.	Check the connection between the fan located on the side of the board shield and the SY board, or replace the fan.
18	OPTICAL UNIT TEMPERATURE ALERT	The temperature of the optical unit is too high, or the harness is disconnected or down.	The ventilation hole for intake on the projector may be blocked. Check the projector is installed properly.
19	LAMP_A TEMPERATURE ALERT	The temperature of Lamp A is too high, or the harness is disconnected or down.	The ventilation hole for intake on the projector may be blocked. Check the projector is installed properly.
20	LAMP_B TEMPERATURE ALERT	The temperature of Lamp B is too high, or the harness is disconnected or down.	The ventilation hole for intake on the projector may be blocked. Check the projector is installed properly.
21	LAMP_A HOUSE DETACHED	The projection lamp house of Lamp A is detached, or the harness is disconnected or down.	Check the attachment screw on the projection lamp house of Lamp A or the harness.

No.	Error messages	Meaning	Remedy
22	LAMP_B HOUSE DETACHED	The projection lamp house of Lamp B is detached, or the harness is disconnected or down.	Check the attachment screw on the projection lamp house of Lamp B or the harness.
23	REAR COVER DETACHED	The rear cover is open, or the harness is disconnected or down.	Close the rear cover securely.
24	LAMP_A POWER SUPPLY UNIT ALERT	Temporary high temperature or some trouble with the power (ballast) of Lamp A	If the error message is still displayed, check the projector is installed properly, or replace the power supply unit for Lamp A.
25	LAMP_B POWER SUPPLY UNIT ALERT	Temporary high temperature or some trouble with the power (ballast) of Lamp B	If the error message is still displayed, check the projector is installed properly, or replace the power supply unit for Lamp B.
26	LAMP_A IGNITION FAILURE	Lamp A does not turn on.	Replace Lamp A.
27	LAMP_B IGNITION FAILURE	Lamp B does not turn on.	Replace Lamp B.
28	CPU ALERT	Trouble with the main CPU (IC301) on the SY-321. Serious trouble	Turn off the power, then turn it on again. If the error message is still displayed, replace the SY board with a new one.
29	MUTING OFF FAILURE DOUSER OPEN FAILURE	Trouble with opening/shutting of the shutter, or the harness is disconnected or down.	Check the motor of the shutter or replace it with a new one.
30	INPUT BOARD FAN FAILURE	Trouble with the axial fan next to the INPUT A/B/C/D boards, or the harness is disconnected or down.	Check the connection between the fan located on the front of the board shield and the SY board, or replace the fan with a new one.
31	REAR FAN ALERT	Trouble with the huge axial fan at the rear, or the harness is disconnected or down.	Check the connection between the rear fan and the SY board, or replace the fan with a new one.
32	LOW REAL TIME CLOCK BATTERY	The RTC battery (BT201) for the SY-321 board should be replaced.	Replace the BT201 RTC battery for the SY-321 board with a new one.
33	FPGA CONFIG FAILURE	The internal line of the projector does not function properly.	Turn off the power of the projector, then turn it on again.
34	IIC FAILURE	The internal line of the projector does not function properly.	Turn off the power of the projector, then turn it on again.
35	LAMP A ALERT	The time used for Lamp A exceeds the recommended time for replacement.	Replace the projection lamp of Lamp A with a new one.
36	LAMP B ALERT	The time used for Lamp B exceeds the recommended time for replacement.	Replace the projection lamp of Lamp B with a new one.
37	LAMP A WARNING	The time used for Lamp A exceeds 80% of the recommended time for replacement.	Place an order for the projection lamp.
38	LAMP B WARNING	The time used for Lamp B exceeds 80% of the recommended time for replacement.	Place an order for the projection lamp.
39	DATA LOAD FAILURE LENS POSITION SENSOR	Failure of the lens position adjustment to the registered setting.	Check the projector is installed properly, then redo the setting again. If the error message is still displayed, inspect the lens and have it repaired if necessary.
40	PS FAN FAILURE	Trouble with the fan for PS converter, or the harness is disconnected or down.	Check the fan located at the upper part of the PS converter is connected to the SY board correctly, or replace the fan with a new one.
41	DVI SIGNAL FAILURE	Inappropriate menu setting for the input signal has been found, or the cable has been disconnected or is down. The message is displayed only if the above situation occurs when LKRI-004 or LKRI-005 is attached.	Check that the menu setting in the PICTURE CONTROL window is appropriate for the input signal, or the connecting cables are connected correctly.

Dimensions

External Dimensions

Front

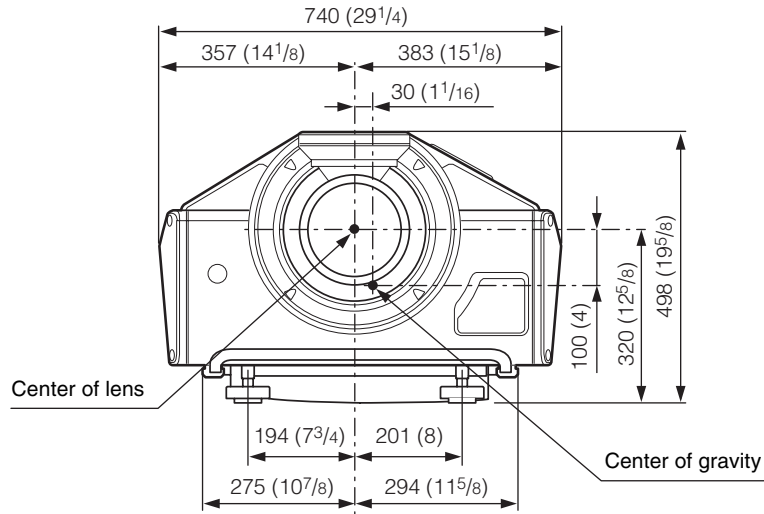

Unit: mm (inches)

Side

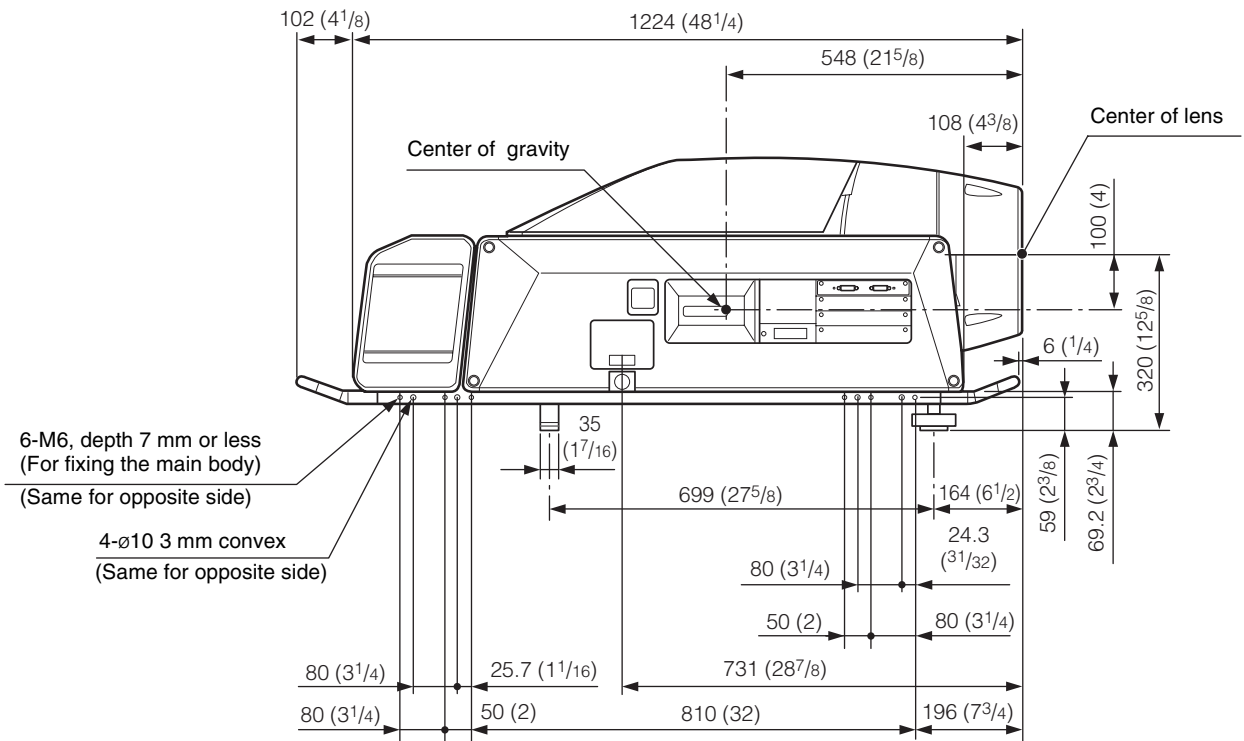

Unit: mm (inches)

Top

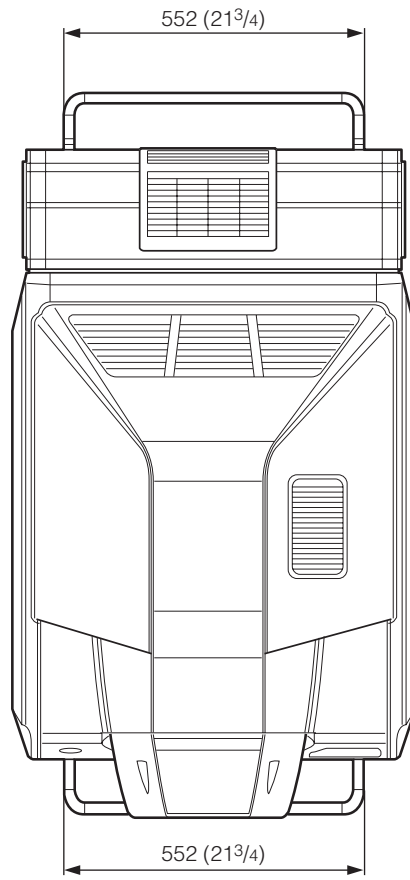

Unit: mm (inches)

Mounting Platform Dimensions

Indicates the dimensions of the recommended shape for the projector attachment parts.

Material

Mounting platform: SECC, 3.2 mm ($\frac{5}{32}$ inch) thickness

Bolt: SWCH M6 × 12 mm ($\frac{1}{2}$ inch) (for the mounting platform with 3.2 mm ($\frac{5}{32}$ inch) thickness)

Notes

- The mounting platform is symmetric with respect to a point.
- Holes other than $\varnothing 8$ are clearance holes for the projector.
- Use M6 washers and spring washers for the M6 bolts (× 12) when fixing the projector.

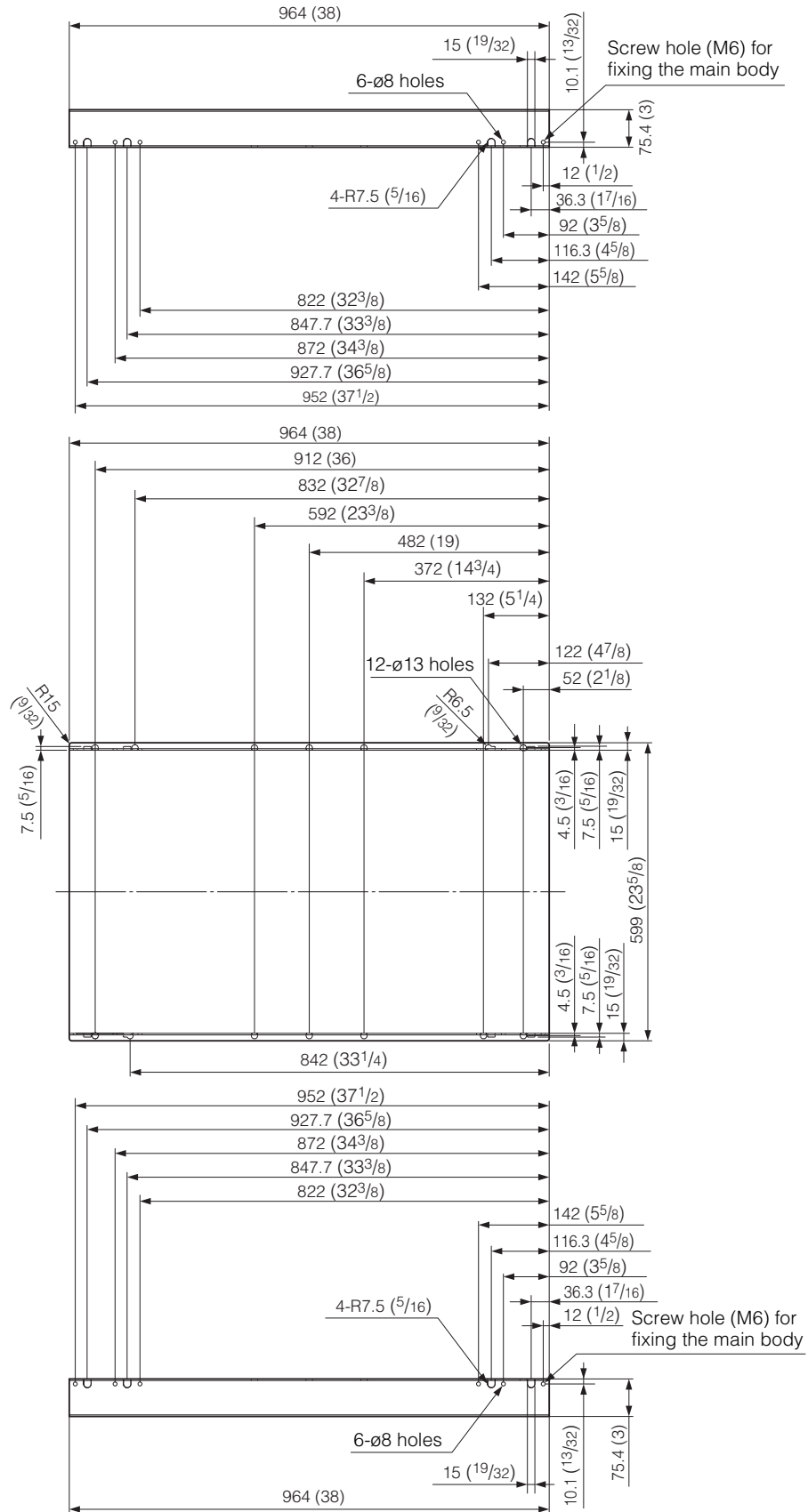

Unit: mm (inches)

Necessary Clearance for Installation and Maintenance

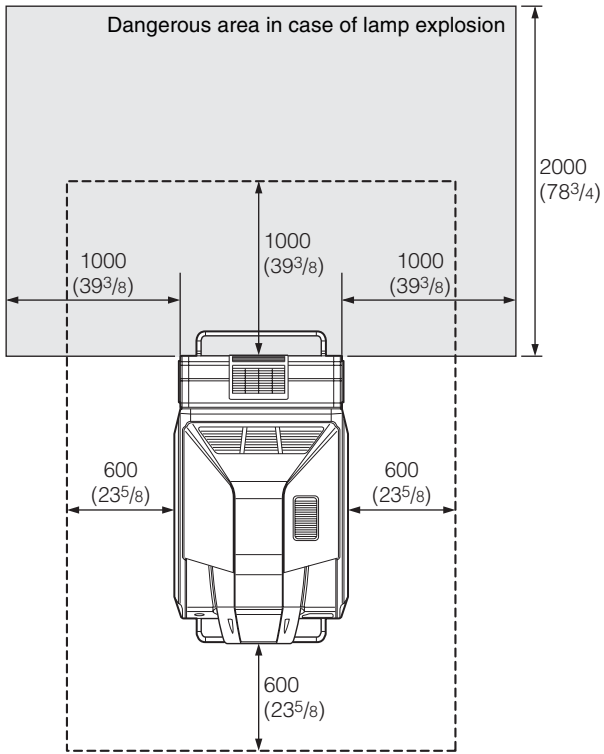

Unit: mm (inches)

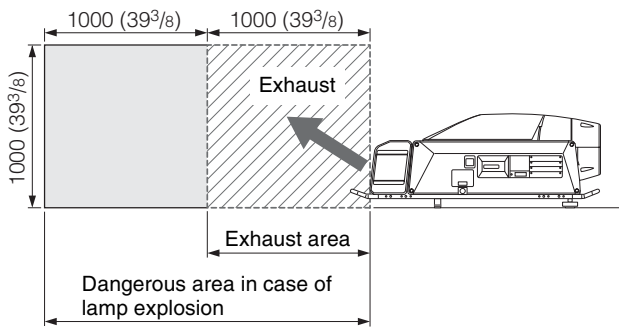

Unit: mm (inches)

Displayed Image Size in Multiple Screen Mode

Unit: pixel

Screen mode Type of signal	Single screen		Dual screen		Quad screen	
	Horizontal size	Vertical size	Horizontal size	Vertical size	Horizontal size	Vertical size
VIDEO60	2880	2156	2003	1499	1440	1078
VIDEO50	2880	2146	2003	1504	1440	1073
XGA	2849	2137	2048	1536	1432	1074
SXGA1	2560	2048	2048	1638	1280	1024
SXGA2	2560	1920	2048	1536	1280	960
SXGA+	2800	2100	1400	1050	1400	1050
UXGA ^{a)}	2864	2148	1600	1200	–	–
WUXGA ^{a)}	3437	2148	1920	1200	–	–
720p	3810	2143	2048	1152	1916	1077
HD	3840	2160	1920	1080	1920	1080
2K	4096	2160	2048	1080	2048	1080
4K	4096	2160	–	–	–	–

^{a)} When projecting signals with vertical frequency of more than 1080 pixel such as UXGA and WUXGA in quad-screen mode, a part of the displayed image may be invisible.

Index

- A**
- About the Display Mode 6
 - Adjustments and Settings Using the SRX Controller 24
 - Attaching the Lens 12
- B**
- Board 25, 27
 - Brightness 26
- C**
- Color 26, 27
 - Color Space 27
 - COLOR SPACE CONVERTER 31
 - Color Temp 27
 - COLOR/FRAME window 27
 - Connections
 - component/video GBR equipment 18
 - computer equipped with a DVI-D connector 16
 - computer equipped with an analog RGB connector 17
 - HD-SDI equipment 17
 - power cord 18
 - Contrast 26
 - Control Function Menu window 24
 - Controlling PC Destination 22
 - Correcting the Color Characteristics 32
- D**
- Date & Time 20
 - Dimensions 38
 - Displayed Image Size in Multiple Screen Mode 42
 - Dot Phase 28
 - Dual 29
- E**
- ELECTRIC V SHIFT FUNCTION 28
 - Error Messages 36
 - Exhaust duct adaptor 5, 15
- F**
- fH 26
 - Focus 28
 - Frame Adjust 28, 34
 - FUNCTION 1-7 24
- G**
- Gamma 27
- H**
- H Shift 28
 - H Size 28
- I**
- I/P Mode 26
 - IMAGE FLIP 29
 - Input board 14
 - Input Signals And Adjustable/Setting Items 34
 - Input Source 25
 - Install at ± 90 degrees angle 11
 - INSTALLATION window 28
 - Installing Lamp Houses 12
 - Internet Protocol (TCP/IP) 21
 - INTERPOLATION 31
- L**
- Lamp Life 35
 - LAMP POWER 29
 - LAMP SELECT 29
 - LAMP TIMER RESET 31
 - LAN 21
 - LENS CONTROL 28
 - Load 23
- M**
- Mail Report 21
 - Mail Server 21
 - Mounting Platform 11, 39
- N**
- Necessary Clearance for Installation and Maintenance 41
 - Network 21
 - Network Block Reboot 22
- O**
- Optional accessories 5
 - Owner 20
 - Owner Information 20
- P**
- PC Communication 22
 - PICTURE CONTROL window 25
 - Positioning of the projector 11
 - Precautions 4
- Profile** 23
- Program Launcher screen 24
- PROGRESSIVE DISPLAY MODE** 29
- Projection Distance Charts 7
 - Projection lens 12
 - Projector 20
 - Projector Identifying 22
- R**
- Registering the settings 24
 - REGISTRATION ADJUST 31
 - Replacing the lamp 35
 - Report Timing 21
 - Reporting Sources/Destination 21
- S**
- Save 23
 - SERVICE window 30
 - Setting the Projector 20
 - SETTING window 20
 - Sharpness 26
 - Shift 28
 - Signal Adjust 26, 34
 - Signal Info 26
 - Signal Mode 25
 - Single 29
 - SIRCS 29
 - SNMP 22
 - SQUEEZE 29
 - SRX Controller 19, 24
- T**
- TEST PATTERN 30
 - Time Server(NTP Server) 21
 - Time Zone 20
- V**
- V Shift 28
 - VERSION INFORMATION 31
- W**
- WHITE BALANCE 30
- Z**
- Zoom 28

<http://www.sony.net/>

Sony Corporation