

SONY®



4K Digital Cinema Projectors

**SRX-R220/SRX-R210**

Media Block

**LMT-100**

Screen Management System

**LSM-100**



The Combination of "4K" Visuals With a 2000:1 Contrast Enclosure Provides a Desirable Solution for the Digital



# ast Ratio and a Highly Secure, Self-contained Cinema Age.

Sony is proud to introduce an ultra-high-resolution projector system designed specifically for digital cinema applications.

This projector system consists of the SRX-R220/SRX-R210 Digital Cinema Projector, the LMT-100 Media Block, and the LSM-100 Screen Management System, which are used with peripheral equipment such as RAID (Redundant Arrays of Inexpensive Disks) storage, an SMS Server, and an Uninterruptible Power Supply system.

The core component of this system, the SRX-R220 and SRX-R210 projectors, are equipped with three Silicon X-tal Reflective Display (SXRDTM) imaging devices, delivering an amazing resolution of 4096 x 2160 pixels (H x V) - more than four times the resolution of full HDTV (1920 x 1080). The SXRDTM devices also provide a SMPTE-standard brightness level: 14 ft-L\* on a 20-meter (65.6-foot) wide screen for the SRX-R220 and a 17- or 14-meter (55.8- or 45.9-foot) wide screen for the SRX-R210\*\*, along with a high contrast ratio of 2000:1. One of the major characteristics of these projectors is their enclosure design, which encases all of the system components required for exhibition including server, storage, SMS, security and power management. This self-contained design realizes a high security level that meets the FIPS 140-2 SPB-2 anti-tamper regulation stipulated by the Digital Cinema Initiatives, LLC (DCI). It also simplifies installation since everything other than audio and automation is already wired and tested at the factory. Various lenses are available for the SRX-R220/SRX-R210 projector, which provide zoom ratios as short as 1.38x to as long as 7.0x.

The other important components included in this system are the LMT-100 Media Block and LSM-100 Screen Management System which, in combination with the SRX projectors, establishes a highly integrated digital cinema projection system. The LMT-100 Media Block is a digital cinema server that can play back DCI DCP (Digital Cinema Packages) files.\*\*\* The LSM-100 Screen Management System provides a variety of screen management operations such as show scheduling, content ingest, operator roles, and control of standard theater automation systems. Moreover, this software also has various functions to help prevent illegal copying, such as the monitoring of cavity on the enclosure, security key management, and logging of any of security events.

With extremely high resolution, high-quality color tonal reproduction resembling film, and simple integration, the Sony digital cinema projector system based on the SRX-R220/SRX-R210 4K projector is an ideal solution for digital cinema applications.

\* Measured at the screen center of a full pixel size (4096 x 2160) projection with X=3794, Y=3960, Z=3890 white and a screen gain of 1.8. A ft-L (foot-lambert) is a unit of measurement for luminance. One foot-lambert equals 3.4262591 candelas per square meter.

\*\* Tentative

\*\*\* Meeting DCI V1.1 specifications



## CineAlta 4K™

### Experience the Difference With True 4K Digital Cinema

In 1999, Sony introduced a totally new concept for moviemakers to provide a new higher level of picture quality, efficiency, and flexibility in production processes – digital cinema production.

Sony's new approach was to produce movies in a high-definition (HD) progressive video format at 24 frames per second using digital video tape media.

This concept, together with the Sony products that enabled it, was named CineAlta™ – and it has been embraced by an ever-broadening spectrum of producers, directors, and cinematographers all over the world. A large number of movies have already been produced digitally using CineAlta equipment, and this will continue into the future.

The recent acceleration of HD has heightened the need for the best technologies at every point in the professional production workflow. As a result, Sony launched "CineAlta 4K" in 2006 – an extension of the CineAlta brand that currently comprises the SRX Series SXR 4K projectors. Sony is also working to expand the "4K" concept to other Sony professional equipment, with a longer-term plan to establish a 4K production workflow.

With Sony CineAlta 4K technologies and equipment, true 4K digital cinema is a reality.

## System Advantage/Features

### 4K Resolution

Historically, the movie theatre experience has always exceeded what could be achieved by home entertainment systems. The advent of HDTV (1920 horizontal pixels) and technical improvements in home theatre equipment have stimulated the movie industry to think further ahead into the future. Meanwhile, the Hollywood movie studios have jointly agreed on standardizing 4K (4096 horizontal pixels) and 2K (2048 horizontal pixels) as the next-generation digital movie distribution and projection standards. Creating movies in 4K provides a significant attraction to the theatre audience. In recent years, stadium-type seating is becoming increasingly popular among modern cinema complexes. By sitting closer to the screen, the audience can enjoy an immersive visual experience. However, those sitting in the front rows may witness image artifacts if the projection system is at a lower resolution. The SRX-R220 and SRX-R210 provide the full detail of 4K content thanks to Sony's SXR imager, exclusive 4K internal signal processing, and newly designed 4K-compatible optical system. In addition, since the SRX-R220/SRX-R210 provide four times the resolution of 2K projectors, the visual quality of 2K and HD content is also maximized.

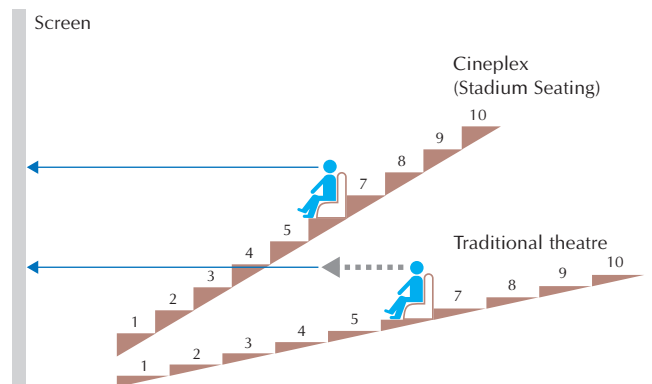

## High 2000:1 Contrast Ratio

The SRX-R220 and the SRX-R210 offer a high contrast ratio of more than 2000:1\* through the use of Sony's unique SXRD device and proprietary optics. The SXRD imaging device itself achieves a contrast ratio of over 4000:1. This stunning picture quality makes the SRX-R220 and SRX-R210 ideal for cinema exhibition.

The high contrast ratio has been achieved through three key technologies - the 'Vertically Aligned Liquid Crystal' system, an extremely thin liquid crystal cell gap, and a new optical path design.

\* The contrast ratio is measured from a screen offering a gain of 1.0.

## Xenon Lamp Provides Highly Bright and Pure Light Source

The SRX-R220 provides a high brightness of 14 ft-L\* on a 20-meter (65.6-foot) wide screen, and the SRX-R210 provides the same brightness on a 17- or 14-meter\*\* wide screen using a single Xenon lamp.

A Xenon lamp, standard in all film projectors, provides pure, accurate color tonal reproduction essential to meeting the stringent requirements of digital cinema. The SRX-R220 utilizes a 4.2 kW Xenon lamp, while the SRX-R210 uses either a 3.0 kW\*\* for a maximum of 13000 lumens or a 2.0 kW\*\* Xenon lamp for 8000 lumens. Lamps are available from Sony or many other lamp manufacturers.

\* Measured at the screen center of a full pixel size (4096 x 2160) projection with X=3794, Y=3960, Z=3890 white and a screen gain of 1.8. A ft-L (foot-lambert) is a unit of measurement for luminance. One foot-lambert equals 3.4262591 candelas per square meter.

\*\*Tentative



## Variety of High-quality Lenses

Five optional zoom lenses are available for the SRX-R220 and SRX-R210. All lenses utilize very large glass optical components that contribute to minimizing the optical vignetting (darkening in the corners of the image) that typically occur on smaller projector lenses, while maintaining the highest possible values of MTF (Modulation Transfer Function). With these features, the optical systems of the SRX-R220 and SRX-R210 have the capacity to reproduce resolutions higher than 4K, which is necessary to project 4K content exactly as the artist envisioned. In addition, these lenses are designed to minimize chromatic aberrations using Sony's advanced optical technology.



LKRL-Z114C

LKRL-Z116C

LKRL-Z117



LKRL-Z119

LKRL-Z122

## Variety of Interfaces

The SRX-R220 and SRX-R210 support a wide variety of signal formats including images using the 12-bit X'Y'Z' signals that are stipulated in the DCI specification. 10-bit 4:4:4 RGB and 10-bit 4:2:2 YPbPr signal formats are also supported for playback from other alternative sources.

- Two channels of SRLV which are used for connection to the Image Media Block (for 4K exhibition).
- A dual-link HD/DC-SDI input that accepts any of the following signals: SMPTE 372M dual-link HD-SDI (4:4:4), SMPTE 292M HD-SDI (4:2:2), dual-link DC-SDI (RGB 4:4:4), DC-SDI (YPbPr 4:2:2), or 12-bit (X'Y'Z' 4:4:4) signals (for 2K projection or HD projection).
- A DVI interface that accepts DVI signals for up to 2048 x 1080 at 60 Hz.

\*The DVI input does not support HDCP or HDMI format signals

	Resolution	Remarks
1	1024 x 768 at 60 Hz (XGA)	VESA
2	1280 x 960 at 60 Hz (SXGA1)	VESA
3	1280 x 1024 at 60 Hz (SXGA2)	VESA
4	1400 x 1050 at 60 Hz (SXGA+)	VESA
5	1600 x 1200 at 60 Hz (UXGA)	VESA
6	2048 x 1080 at 60 Hz (DC)	
7	1920 x 1080 at 24 Hz (HD)	
8	2048 x 1080 at 24 Hz (DC)	
9	1920 x 1200 at 59.95 Hz Reduced Blanking (WUXGA)	VESA
10	1920 x 1080 at 60 Hz (HD)	EIA/CEA-861B
11	2048 x 1080 at 48 Hz (DC)	

# Operational Features

## Color Space Conversion (CSC) function

The SRX-R220 and SRX-R210 features a Color Space Conversion (CSC) function, which helps users easily adjust the projector's color space to that which is defined in the DCI (Minimum D-Cinema Color Gamut) or ITU-R BT.709. The target color gamut parameters required to display feature exhibition or alternate content can be automatically calculated from settings using the supplied SRX Controller software. The internal test generator simplifies adjustment and lets the operator align the projector in minutes

\*A light meter is required for this adjustment and can be obtained from a test equipment manufacturer.

## 12-bit SXRD Driver

The SRX-R220 and the SRX-R210 utilize a 12-bit imager driver for reproducing extremely natural images.

## Gamma Curve Selection

The SRX-R220 and the SRX-R210 provide three preset gamma curve values. Users can select an optimum value from 1.8, 2.2, and 2.6 according to the desired color tone when displaying alternate content. A 2.6 gamma setting is automatically selected by the system for feature exhibition.

## Squeeze Mode Function

The SRX-R220 and SRX-R210 eliminate the need for an external anamorphic lens. Due to the extremely high resolution offered with the SXRD imager, signal processing can be used to correct the geometric distortion of an anamorphic image allowing automatic compensation between images. Image aspect ratios can be identified in the SMS timeline and automatically activate the squeeze function if required to display any content.

## Keystone Masking

To compensate for keystone distortion, which typically occurs when the projector is not installed perpendicular to the screen, the SRX-R220 and SRX-R210 offer an image-masking function. Alignment through the projector software allows users to set a two center screen points as well as four corner points, which provides compensation for both flat and curved screens.

Select four corner positions to mask the area outside the perimeter.



For curved screens, select two positions at the apex of the curve, one at the top and one at the bottom of the screen.

## Zoom/Focus Memory Function

The SRX-R220 and SRX-R210 are equipped with zoom and focus memory functions that make it easy to switch the projection between scope and flat aspect ratios. Image size can be stored and instantly recalled via the SRX Controller software or the screen management system software. This allows for full-screen display regardless of the aspect ratio. An electronic vertical alignment feature is included in the same memory to compensate for vertical changes in the image should the projector be mounted at a downwards angle.

# Easy Setup and Maintenance

---



Display Not Included

## Easy Maintenance of Luminance Level

During long periods of usage, users commonly have to adjust the luminance level of their projector, as Xenon lamps typically age over time. The SRX-R220/SRX-R210 has a convenient function to help users know when to make such adjustments. The supplied SRX Controller software allows users to set a standard luminance level, and displays an alert message on the LCD screen at the back of the projector when the value changes from the standard level. With this feature, proper and timely maintenance of the luminance level or lamp can be performed.

## Automatic Lamp Power Calibration Function

Typically, light levels will change when changing aspect ratios between scope and flat images. To maintain a constant luminance level during these changes, the SRX-R220 and SRX-R210 projectors can automatically calibrate the luminance level by controlling the lamp output power.

## Key Lock System

The SRX-R220 and SRX-R210 are designed to be highly secure in response to DCI requirements. They do not have screw holes, but require physical keys to open the enclosure. This body structure meets FIPS 140-2 SPB-2 anti-tamper regulation stipulated by the DCI. Even if the enclosure is opened with the physical keys, an anti-tamper sensor will trigger the Media Block LMT-100 to immediately start recording logs for further safety if the exhibitor has not authorized the entry. In this case, these projectors also delete Key Delivery Messages (KDM) automatically, so that DCP files cannot be played back.

\*The decision for who has access to the system is defined by the exhibitor. Control of this is through the screen management system and related operator role settings.

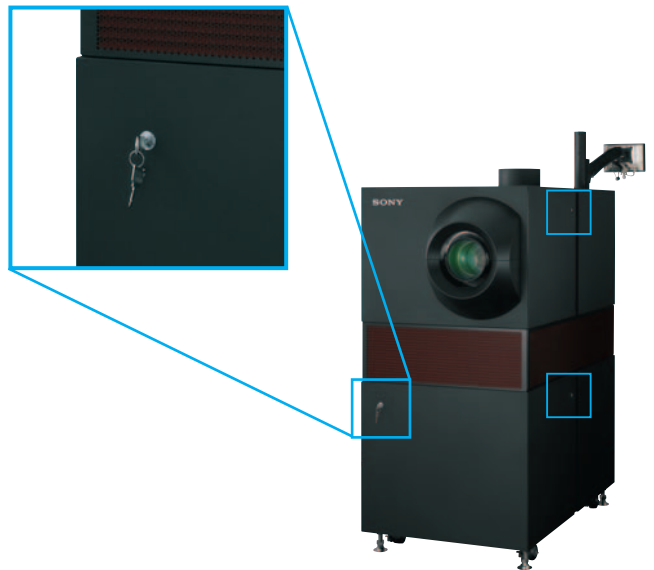

In addition to their extreme resolution and high contrast, the SXRD devices used in the SRX series projectors have the following remarkable technological features:

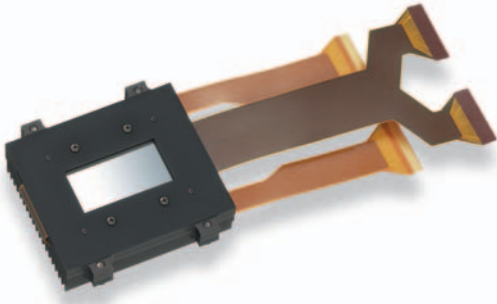

## Vertically Aligned Liquid Crystal System

In every type of projector system, displaying absolute black is a major issue in order to achieve a high contrast ratio. In other words, the contrast ratio of a projector depends on how effectively the light from the source can be blocked so it does not leak through the imager.

All Liquid Crystal on Silicon (LCOS) devices control the amount of light to be projected by applying an electric field to the crystal gap. In typical LCOS devices, black is produced when an electric field is applied across the cell gap. However, molecules near the surface of the glass substrate may not be accurately controlled due to the influence of the alignment film. This is not an issue for bright images. However, when displaying dark images, light may tend to leak from the LCOS device, since the molecules near the surface are less accurately controlled. This results in a creamy black instead of a deep black.

The SXRD device does not exhibit these characteristics. This is because the Vertically Aligned Liquid Crystal system displays black when the electric field is not applied and because all molecules are in the correct alignment, with no charge applied. The direct result is a far deeper black level, leading to a high contrast ratio.

## Thin Crystal Cell Gap

Another important enabling factor of high contrast is the SXRD device's ultra-thin cell gap which is less than 2 micrometers thick. In conventional Vertically Aligned Liquid Crystal systems, a thin cell gap could not be achieved. Sony has overcome this difficulty through the use of Sony's innovative planarization technology in the silicon backplane structure and an advanced Silicon wafer-based assembly process.

The SXRD device also adopts a cell structure that does not use "spacers". These are columns found in conventional LCOS devices to maintain a constant gap between the cell floor and the top of the device. Spacers tend to both scatter and reflect light, which can impair high-contrast pictures. In the spacer-less SXRD device, these artifacts are no longer visible.

## Short Response Time

The thin cell gap structure in SXRD devices also contributes to an ultra-fast response time of 5 milliseconds. The SXRD device reacts promptly to an instantaneous change of picture content, enabling it to display smooth and natural motion. Consequently, the SRX-R220 and SRX-R210 virtually eliminate motion blur; a particularly significant benefit for visual content that includes fast-moving objects.

## Reliable Imaging Device

The SRX-R220 and the SRX-R210 use a very high-power lamp. As a result, special attention has been paid to the reliability of the SXRD device. The inorganic materials utilized for the alignment layer of the SXRD imager are resistant to deterioration or deformities that could occur due to the intense heat and light generated by using a large lamp system.

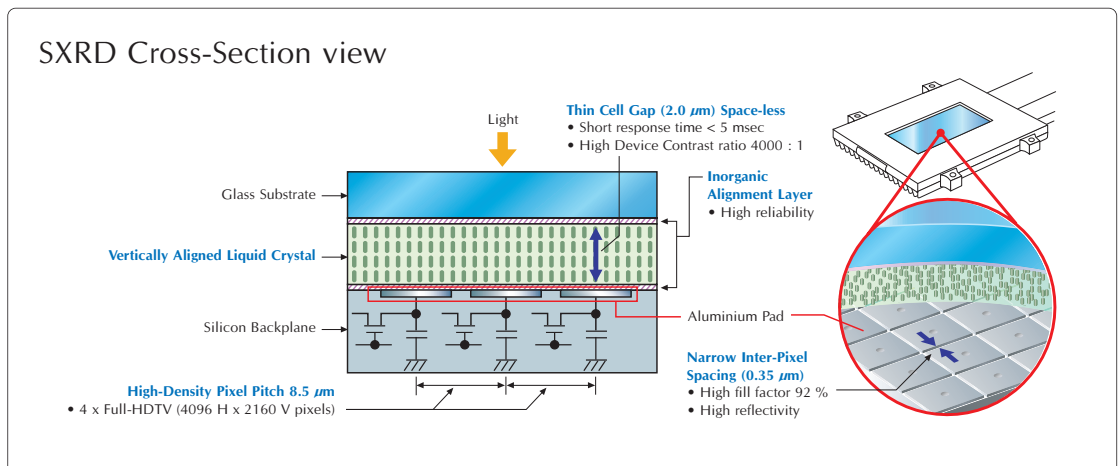

# Digital Cinema Server - LMT-100 Media Block



The LMT-100 Media Block is a digital cinema server that can handle DCI DCP files, which is a key component in establishing secure theatre systems.

The LMT-100 server handles DCP (Digital Cinema Packages) files that consist of picture, audio, and subtitle data files, and that are wrapped into an MXF (Material eXchange Format) file. It can play back the DCP file by using advanced processing to decrypt and decode the picture data, and then send it to the projector over a secure multi-pin connection system.

The LMT-100 server is controlled with the SMS (Screen Management System) software.

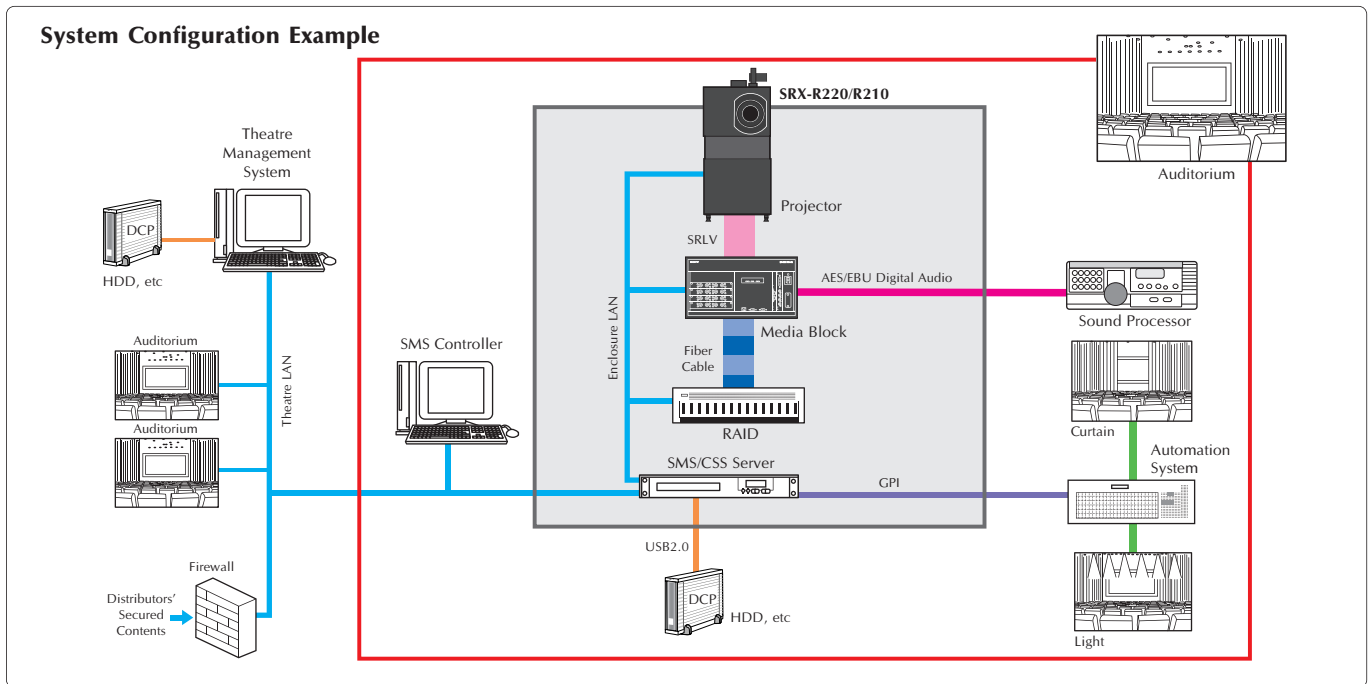

## Decryption and Unwrapping of DCP Files

The LMT-100 can decrypt DCP files that have been encrypted using the AES (Advanced Encryption Standard PSP 197). It can also unwrap individual picture, audio, and subtitle data files for processing that are encoded within the MXF file.

## Picture and Subtitle

The LMT-100 can decode the JPEG 2000 picture data in real time for playback, regardless of whether the file was encoded at 2K or 4K resolution. Subtitles in Timed-Text/XML or PNG/XML format can be overlaid onto picture data before it is sent to the projector.

## Audio

The LMT-100 transcodes audio DCP files into AES/EBU digital audio signals, and then outputs them to external audio processors. Up to 16 channels can be output from D-sub 25-pin or BNC connectors. The timing of the audio output can be adjusted for complete synchronization with the picture, and any channel can be routed to any output to simplify installation.

# Screen Management System - LSM-100



The LSM-100 Screen Management System is a software application that controls a host of components including: LMT 100 Server, SMS controllers, projectionist terminals, CSS (Cavity Security system) servers, power equipment, and status lights. For these controls, a variety of functions are provided. It also provides seamless integration with other systems in the theatre such as the Theatre Management System and the auditorium automation system. The LSM-100 satisfies the requirements of DCI Specifications version V1.1 for screen management and security.

## Supported Functions

### Screen Management Functions:

- Content ingest/registration and content management
- KDM registration and key management
- Show Play List (SPL) management
- Show schedule management
- Playback control
- Composition of SPLs
- Device configuration
- Device monitoring
- Auditorium setup
- Status monitoring: collect status information from projector, Media Block, RAID, and Cavity Security System; report status at pre-configured intervals
- Log retrieval: including log filtering and secondary log distribution
- Automation system interface
- Interface (XML/HTTPS) transfer to external TMS system

### Security Functions:

- Monitoring of cavity security sensors
- Notifying Media Block LMT-100 and CSS of cavity sensor events
- Responding to security queries made by Media Block LMT-100
- Keeping diagnostic logs of security events

### Power Management Functions:

- Status monitoring: monitor status of RAID during power-up sequence
- IP traffic monitoring: listen for IP messages from UPS signaling abnormal power and UPS battery conditions
- IO monitoring: monitor power state change requests via projectionist terminals
- Monitors the enclosure power lamp to show current power status
- Sequence power provided to component devices during power-up and power-down transitions, both user-requested and unplanned utility outages
- Control UPS during unplanned utility outages
- Initiate standby/shutdown sequences for SRX projector, Media Terminal, SMS Server, UPS
- Initiate startup/power-on sequences for UPS, RAID, Media Terminal, SMS Server
- Provides GUIs with status indication

### Management of system access and operator roles:

- Lets the exhibitor and or subtract employees access to the system
- Sets levels of access to the system on a person/responsibility level

# Dimensions Unit: mm (inches)

SRX-R220/SRX-R210

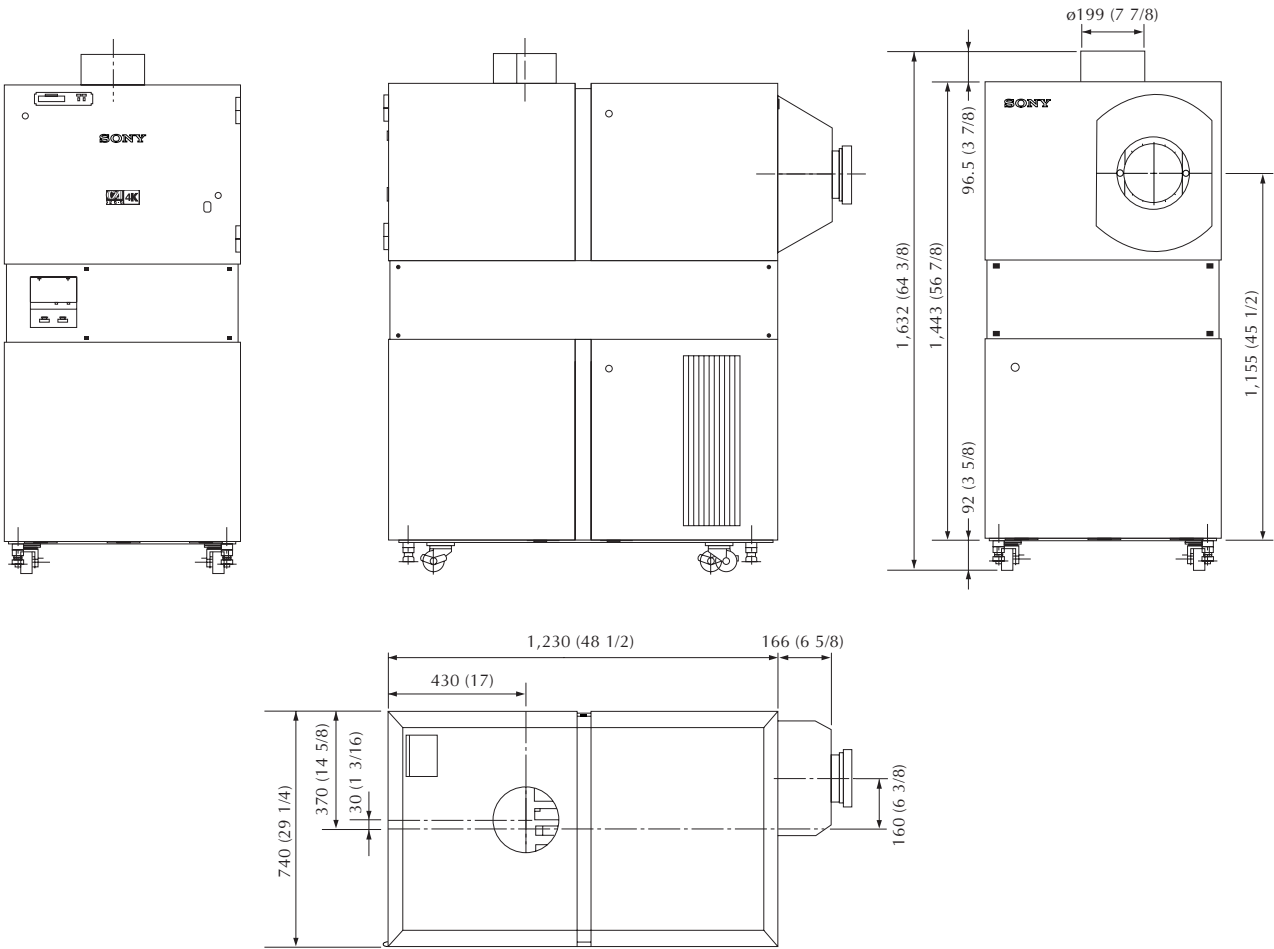

Server and SMS system is enclosed within the projector  
 Above are (top to bottom)  
 LMT 100 media Block  
 SMS computer  
 Two Terabyte Raid system for content storage

# Accessories



LKRL-Z114C  
x1.35 to x1.98 zoom lens



LKRL-Z116C  
x1.50 to x2.29 zoom lens



LKRL-Z117  
x1.73 to x2.41 zoom lens



LKRL-Z119  
x1.81 to x2.94 zoom lens



LKRL-Z122  
x2.23 to x3.92 zoom lens

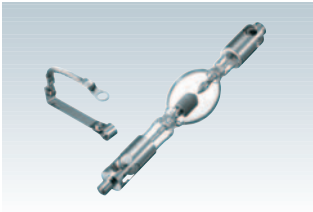

LKRX-2042A  
4.2 kW Xenon lamp bulb for  
replacement (for SRX-R220)

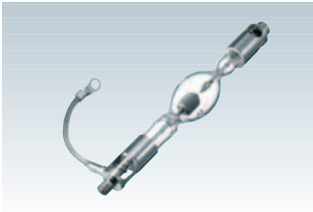

LKRX-2030A  
3.0 kW\* Xenon lamp bulb for  
replacement (for SRX-R210)

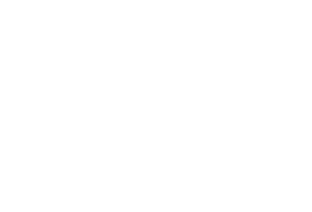

LKRX-2020A  
2.0 kW\* Xenon lamp bulb for  
replacement (for SRX-R210)

\* Tentative

# Specifications (SRX-R220/SRX-R210)



## SXRD Device Main Specifications

Display device	SXRD (Silicon X-tal Reflective Display)
Size	1.55-inch across Diagonal
Resolution	4096 (H) X 2160 (V) Pixels
Contrast	More than 4000:1
Pixel pitch	8.5 $\mu\text{m}$
Width (between pixels)	0.35 $\mu\text{m}$
Response speed	5 msec (tr + tf)
Crystal mode	Vertical Aligned Mode
Alignment layer	Inorganic Thin Film
Backplane process	0.35 $\mu\text{m}$ MOS Process
Liquid crystal cell gap	Less than 2 $\mu\text{m}$

## Optical

Projection system	3-SXRD panel, prism color integrated system
Imaging device	SXRD, 1.55-inch (diagonal), 4096 (H) x 2160 (V) pixels on each chip
Lamp	SRX-R220: 4.2 kW Xenon lamp x 1 SRX-R210: 3.0 kW** Xenon lamp x 1 or 2.0 kW** Xenon lamp x 1
Screen coverage (Approx.)	SRX-R220: 4.5-meter to 20-meter screen width on Scope size (4.2 kW lamp) SRX-R210: 4.5-meter to 17-meter screen width on Scope size (3.0 kW lamp)** 4.5-meter to 14-meter screen width on Scope size (2.0 kW lamp)**
Light output	SRX-R220: 18000 lumens SRX-R210: 13000 lumens (3.0kW lamp) 8000 lumens (2.0kW lamp)

\* Measured at the screen center of a full pixel size (4096 x 2160) projection with X=3794, Y=3960, Z=3890 white and a screen gain of 1.8. A ft-L (foot-lambert) is a unit of measurement for luminance. One foot-lambert equals 3.4262591 candelas per square meter.

\*\*Tentative

## General

Colorimetry	Color Primaries		
	Encoding Primaries	x	y
	R	0.6800	0.3200
	G	0.2650	0.6900
	B	0.1500	0.0600
White reference	White reference		
		x	y
	DCI Specification	0.314	0.351
	Virtual White Releases	0.319	0.334
	Alternate Content	0.313	0.329
Contrast	Over 2000:1		
Input signal	Media Block input x 2: Twin SRLV Outputs		
	HD-SDI/Dual-link HD-SDI: 1920 x 1080 pixels (SMPTE-372M/SMPTE-292M/ITU-R.BT709/BTA-S004)		
	DC-SDI/Dual-link DC-SDI: 2048 x 1080 pixels 12 bit'X'Y'Z'		
	(through Dual-link HD/DC-SDI Input Board)		
	DVI-D: XGA (1024x768) / SXGA1 (1280x960) / SXGA2 (1280x1024) / SXGA+ (1400x1050) / UXGA (1600x1200) / WUXGA (1920x1200) / HD (1920x1080) / DC (2048x1080)		
Power consumption	SRX-R220: 1.2 kW (Single-phase/100-240VAC for main circuit) / 5.2kW (3-phase/ 200-208VAC or 380-415VAC selectable for lamp)		
	SRX-R210: 1.2kW (Single-phase/100-240VAC for main circuit) / 3.4kW** (3-phase/ 200-208VAC or 380-415VAC selectable for lamp)		
Power requirements	AC 100 to 240 V, 50/60 Hz, single-phase (for Main power)		
	AC 200 to 208 V / AC 380 to 415 V, 3-phase(changeable), 50/60 Hz (for Lamp power)		
Operating temperature	+5°C to +35°C (+41°F to +95°F)		
Storage temperature	-20°C to +60°C (+12°F to +140°F)		
Operating humidity	35% to 85% (without condensation)		
Storage humidity	10% to 90%		
Dimensions (W x H x D)	740 x 1535 x 1395mm		
	(29 1/4 x 60 1/2 x 55 inches)		
Mass	544kg (1200 lbs) including LMT 100 and SMS computer system		
Fan noise	65 dB or less		

Input/Output	
Input A	DVI-D
Input B	Dual-link HD/DC-SDI
Input C	A channel For Media Block INPUT-A (SRLV connection)
	B channel For Media Block INPUT-B (SRLV connection)
Remote interface	D-sub 15-pin, RS-232C (female) x 1
	Ethernet terminal, 10Base-T/100Base-TX x 1
Interlock	D-sub 15-pin (female) x 1

Others	
Safety regulations	[UL60950 listed], [cUL60950], [FCC Class A], [IC Class A], [VCCI Class A], [EN60950], [CE Class A], [C-tick], [GB4943], [GB9254], [K60950], [CISPR22], [CISPR24]
Supplied accessories	Attachment base plate kit for Touch Panel Controller x 1 Operation instructions x 1 Status Light x 1 Touch Panel Controller Attachment kit x 1
Required specifications for control PC	OS: Microsoft Windows XP Professional Edition (English and Japanese) with Service Pack 2 Required Memory: 256 MB or more HDD Capacity: 8 MB or more Equipped with: 10Base/100Base-TX Ethernet Connector RS-232C Connector Display with XGA or larger CPU: Windows XP: Intel® Celeron® 1 GHz or faster (recommendation)

© 2007 Sony Electronics Inc. All rights reserved.  
Reproduction in whole or in part without permission is prohibited.  
Features and specifications are subject to change without notice.  
All non-metric weights and measures are approximate.  
Sony is a registered trademark of Sony Corporation.  
CineAlta, CineAlta 4K, SXR, and SXR logo are trademarks of Sony Corporation.  
Microsoft and Windows are registered trademarks of Microsoft Corporation.  
VistaVision is a registered trademark of Paramount Pictures Corporation.  
CinemaScope is a registered trademark of 20th Century Fox Film Corporation.  
Intel and Celeron are registered trademarks of Intel Corporation.  
All other trademarks are property of their respective owners.

